



325LA

Broadband Power Amplifier



HIGH RF VOLTAGES MAY BE PRESENT AT THE OUTPUT OF THIS UNIT. All operating personnel should use extreme caution in handling these voltages and be thoroughly familiar with this manual.

Do not attempt to operate this unit prior to reading this manual.

The material contained in this document is the property of Electronics & Innovation Ltd., it is subject to change without notice.

Warranty

Electronics & Innovation Ltd., (hereafter E&I) warrants for the period of three years from the date of original delivery, each unit to be free of defects in materials and workmanship. For the period of 36 months E&I will, at its option, repair or replace defective parts so as to render the unit fully operational such that it performs according to the original specifications; free of charge to the original purchaser.

Should warranty service be required, the unit must be returned to E&I, freight cost to be borne by the owner. If, in our opinion, the unit has been damaged by use outside the limits prescribed in this manual or by accident, then the warranty shall not be honored. In such a case E&I will provide an estimate for repair, assuming repair is possible and provide a quote at standard service rates.

Contents

Chapter 1	
General Information.....	3
Chapter 2	
Operation.....	4
Chapter 3	
Technical Information.....	7
Chapter 4	
Maintenance.....	8
Chapter 5	
Safety.....	12

The material contained in this document is the property of Electronics & Innovation Ltd., it is subject to change without notice.

Chapter 1 Introduction

1.1 Introduction

The E&I Model 325LA is an all solid state amplifier which has a flat frequency response from 250 kHz to 150 MHz. It provides up to 25W of linear power with low harmonic and intermodulation distortion. Gain is 50 dB nominal, with variation of less than +/-1.5 dB over the entire frequency range. Input and output impedances are 50Ω and the unit may be driven to full power output by most RF synthesizers, signal generators and swept signal sources.

The E&I Model 325LA will provide its rated forward power output into any load impedance, regardless of match. It will absorb the power reflected from a mismatched load without causing failure or oscillation.

Forward and reflected RF power is displayed on the front panel meter. The Model 325LA is packaged for bench mounting and can be supplied with rack mounting adapters. It has an integral power supply which operates from an 100 – 264 VAC 47 - 63 Hz main supply.

The Model 325LA will raise the power level of signal sources and generators without requiring tuning or band-switching. The Class A linear circuitry will amplify signals of AM, FM, SSB, TV and complex modulations, limited only by their peak input and bandwidth, with minimum distortion.

1.2 Specifications

Physical and electrical specifications are listed in Figure 1.

1.3 Instrument Identification

Each amplifier is identified by a serial number tag on the back panel of the unit. Both the model number and the serial number should be given in any correspondence with the company.

Chapter 2 Operation

2.1 Introduction

The E&I 325LA RF amplifier is used to increase the RF output level of signal sources in the 0.25 to 150 MHz range. No tuning or any other form of adjustment is required.

2.2 Mains Voltage Setting

The unit automatically adjusts to accommodate the available AC line voltage.

The material contained in this document is the property of Electronics & Innovation Ltd., it is subject to change without notice.

2.3 Mains Fuse Rating

The Mains Fuse FI is located on the rear panel. The replacement part number is F981-ND

2.4 Rack Installation

In order to install the Model 325LA in a standard 19 inch relay rack, the mounting brackets must be attached to the cover as follows:

- a. Remove the four feet on the underside of the amplifier if the minimum vertical usage of the relay rack is necessary.
- b. Remove the two M4-10 screws located on each side of the cover nearest the front panel.
- c. Attach the rack mounting brackets to the sides of the unit using the screws removed in step (b).

2.5 Mains Lead Connection

The unit comes supplied with a 6 foot mains cord.

2.6 Cooling

When the 325LA is enclosed by an external cabinet, provisions must be made to ensure an adequate flow of cooling air to the unit. Ambient temperature of the air must not exceed 40° C.

2.7 Proceed as follows:

- (i) Ensure that there is at least 3" / 7.5 cm clearance at the rear of unit for air flow.
- (ii) Ensure RF input voltage is not excessive
 - a. The 1 V rms indicated maximum input voltage is 5 times the level of the input signal required to achieve maximum output. Input voltages in excess of 2 volts peak may permanently damage the instrument.
- (iii) Connect the output via a 50 ohm coaxial lead and BNC plug to the load.
- (iv) Connect the input signal via a 50 ohm coaxial lead and BNC plug to the input connector.

The material contained in this document is the property of Electronics & Innovation Ltd., it is subject to change without notice.

2.8 Front Panel Display

The 325LA front panel has a passive LCD display designed for simplicity and ease of use. During initialization, the LCD shows the software revision.

Pf: ___W Pr: ___W
Status: _____

Figure 2.1 : Front Panel Display

After the amplifier is initialized, the LCD indicates Forward Power, Reflected Power, and amplifier status (see figure 2.1). Where Pf refers to forward power, Pr refers to reverse power, and Status indicates “OK” unless there is a fault condition, such as:

- Overheat (heat-sink temperature is too high for reliable operation)
- PSU fault (internal fault in the main switching power supply)

In the event of a fault, the unit may be reset by either cycling the power or via the RS 232 interface. In the case over an over temp fault, ensure that the air inlet and out let are unclogged and unrestricted. If the fault persists, please contact E&I or your local representative.

2.9 RS 232 Interface

The 325LA features a standard RS-232 serial interface suitable for connection to a PC or host system. The communication protocol is extremely simple to facilitate readback and control with readily available terminal programs such as Hyperterm. The RS-232 link has the following parameters:

Baud rate: 19200
Data bits: 8
Parity: none
Stop bits: 1
Flow control: none

The material contained in this document is the property of Electronics & Innovation Ltd., it is subject to change without notice.

An example configuration using HyperTerminal on a PC is shown in figure 2.2.

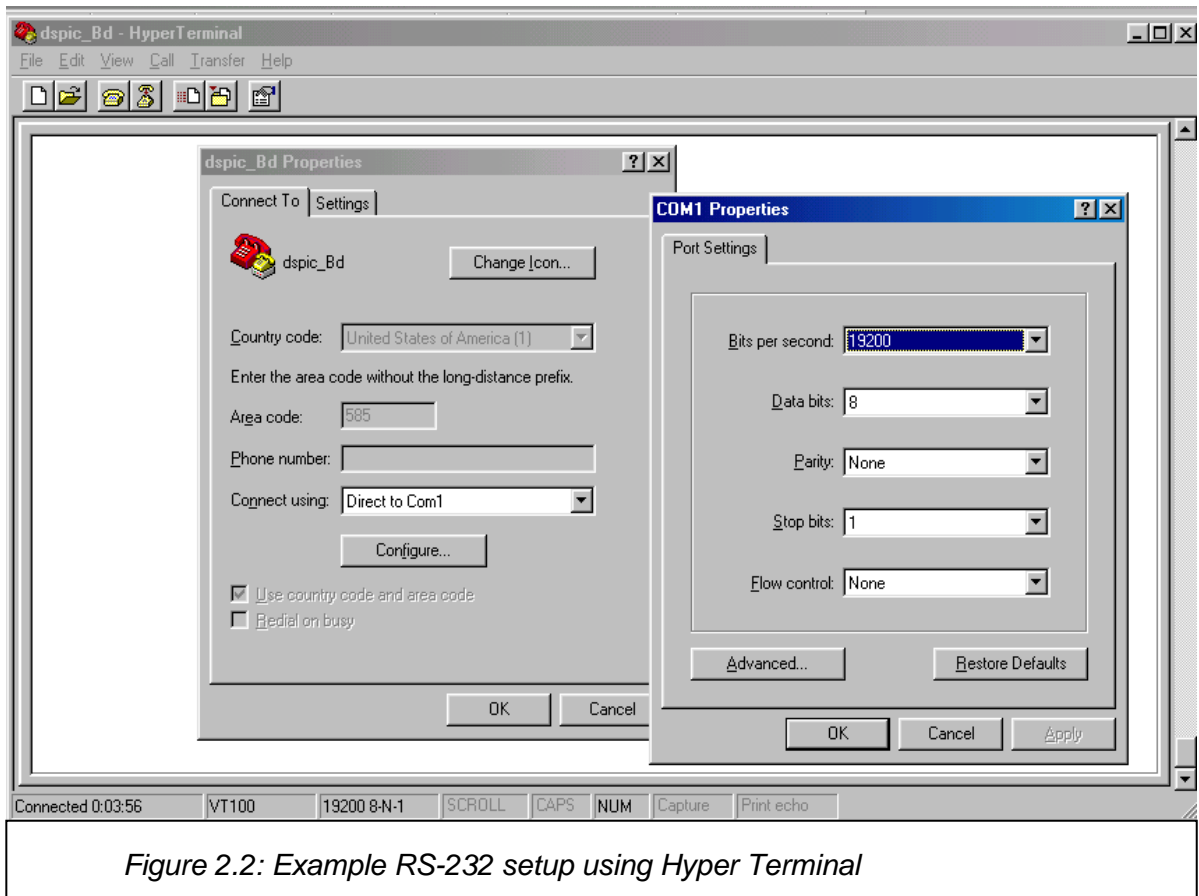

In the default state, the RS-232 port will echo the same information sent to the front panel LCD display, allowing a running datalog to be stored to disk using the capture feature of the terminal program.

Single character commands can be sent to the amplifier to achieve the following:

"1" key enables telemetry (readback similar to LCD display) - this is the default mode at power up

"2" key clears any faults and tries to restart the supply.

"0" key disables any telemetry. (Complement to "1" key)

Custom commands and display lists can be implemented upon customer request.

The material contained in this document is the property of Electronics & Innovation Ltd., it is subject to change without notice.

Chapter 3 Technical Description

3.1 GENERAL DESCRIPTION

The E&I Model 325LA is a linear Class A amplifier capable of increasing the output of any signal generator, frequency synthesizer, sweep generator or laboratory signal source from 250 kHz to 150 MHz. The Model 325LA is completely protected against damage due to load mismatch provided that the input RF level does not exceed 1 VRMS or 1.4V peak. If the attached signal source is capable of generating substantially more than this input voltage, please use caution in adjusting it. The Model 325LA will saturate well before the maximum input voltage and there will be no increase in output power at that point. The 325LA is unconditionally stable. Any impedance can be connected to the input and output of the amplifier, without causing oscillation. The 325LA will deliver its rated power to any load impedance regardless of match. Load mismatch will cause RF power to reflect back to the amplifier. The unit is designed to withstand 100% reflected power (a pure reactance open or short circuit load will cause 100% reflected power) continuously without damage. An output meter is provided to indicate the average forward and reflected power (RMS). Since the meter responds only to average power, the modulation characteristics of the input signal must be taken into account when interpreting the meter readings. For example, the amplifier may be in saturation during the ON portion of a pulse yet the meter reading will be low due to the low duty cycle of the pulse input.

3.2 Control, Indicators and Connectors

The power switch is located on the front panel.

The BNC connectors are marked with the universal symbol for input and output.

The Back Lit LCD display indicated forward and reverse power in addition to the status.

See Figure 2 for Front and Rear panel

3.3 Operating Procedure

Refer to the following procedure as a guide to operating the Model 325LA.

- a. The input and output are connected via the front panel BNC connectors to the signal source and load respectively.
- b. The input signal should be increased gradually while observing the output voltage on the output RF voltmeter.
- c. When the Model 325LA is connected to a 50Ω load, the CW power output of the unit may be read directly from the Display.

3.4 Precautions

The material contained in this document is the property of Electronics & Innovation Ltd., it is subject to change without notice.

- a. The input and output of the Model 325LA should not be connected together. This will cause oscillation and may damage the input preamplifier.
- b. When the input signal voltage of the signal source is unknown, insert an attenuator between it and the Model 325LA input.

3.5 Performance Checks

To determine the amplifier's performance carry out the following procedure.

3.5.1 Initial Check

The following check can be made whenever the condition of the unit is in question.

- (i) Connect power supply. Switch on power and observe that the switch illuminates.
- (ii) Connect the output of the 325LA amplifier to 20 dB attenuator.
- (iii) Connect a calorimetric power meter (HP434 or equivalent) to the output of the attenuator.
- (iv) Connect a sweep generator (Wavetek 2001 or similar) capable of sweeping the frequency range 1 to 150MHz to the input connector, *ensure that the output power of the generator is initially set to minimum.*
- (v) Adjust the output level of the sweep generator to -10dBm.
- (vi) Adjust the input CW signal to any frequency between 1 and 150MHz for 25W output.

If you can not attain RF power, verify that:

- (a) The mains fuse is correctly selected and not blown
- (b) The switch is illuminated.

If the mains fuse is not blown but you are still unable to get any RF power, either return the unit to E&I for repair or proceed to chapter 4.

3.2 Measurement of Gain

Equipment required:

- (a) Two power meters; HP 434 or equivalent
- (b) Sweep/Signal Generator
- (c) 20 dB Coupler
- (d) Attenuator, 20 dB

The material contained in this document is the property of Electronics & Innovation Ltd., it is subject to change without notice.

Connect the equipment as shown in Figure 2, then proceed as follows:

- (a) Increase power from the signal generator to attain an output power measurement of 3 watts as indicated on the output power meter.
- (b) Measure input power and calculate gain. Gain should be a nominal 50 dB
- (c) Vary the frequency of the sweep generator across the band from 250 KHz to 150 MHz. Note that the variation of gain is within +/- 1.5 dB

3.3 Measurement of Harmonics

Equipment required:

- (a) Sweep/Signal generator
- (b) Attenuator, 20 dB
- (c) Power Meter - HP434A
- (d) Spectrum Analyzer

Connect the equipment as shown in Figure 3 then proceed as follows:

- (d) Adjust the sweep/Signal generator at a CW center frequency of 150 MHz for an indicated output of 25W on the power meter.
- (e) Using the spectrum analyzer, check that the level of harmonics are less than -25 dB with respect to the carrier.
- (f) Vary the frequency of the generator from 250 KHz to 150 MHz, the harmonics should remain at -25dBc or below.

Chapter 4 Maintenance

4.1 Introduction

The E&I 325LA RF amplifier requires no periodic maintenance. The instrument is unconditionally stable and is fail safe under all load conditions. Damages can only be externally caused by an input signal in excess of the specified IV RMS maximum.

This chapter therefore, deals only with certain fundamental procedures for fault location and with the subsequent re-alignment procedures.

Performance limits quoted are for guidance only and should not be taken for guaranteed performance specifications unless they are also quoted in Figure 1.

The material contained in this document is the property of Electronics & Innovation Ltd., it is subject to change without notice.

4.2 Packing for Reshipment

In the event of the equipment being returned for servicing it should be packaged in the original shipping carton and packing material. If this is not available wrap the instrument in heavy paper or plastic and place in a rigid outer box of wood, fiberboard or very strong corrugated cardboard. Use ample soft packing to prevent movement. Provide additional support for projecting parts to relieve these of unnecessary shock. Close the carton securely and seal with durable tape. Mark the shipping container FRAGILE to ensure careful handling.

4.3 Access and Layout

NB: Removal of the cover voids the warranty!

The E&I Model 325LA amplifier is housed in an aluminum chassis. A block diagram schematic is illustrated in figure 4. The cover can be removed by releasing the 6 M3 screws on the side of the unit.

The rear panel supports the mains fuse holder, AC line cord and the cooling fan.

4.4 Power supply

The power supply is mounted vertically on the right hand side of the amplifier. It is a wholly self contained unit controlled by the control board.

4.5 The Amplifier Module

The power amplifier module is mounted on the RF heat sink. To remove this module, the RF heat sink must be demounted from the chassis. The RF drive unit sits underneath the PA section

Chapter 5 Safety:

Do not attempt to operate this unit with the cover removed. High AC, RF and DC voltages are present. The cover prevents against electrical shock due to AC line voltages, high DC and RF fields. Further the cover provides part of the cooling system design. Components, specifically on the RF boards are prone to over-heat and eventual failure if the unit is operated without the cover in place.

Ensure that the load is connected to the output prior to connecting the RF input to the unit. This will prevent high voltages being present and exposed at the output connector.

Only use the AC cord provided or equivalent.

Ensure that the mains outlet is properly grounded.

The material contained in this document is the property of Electronics & Innovation Ltd., it is subject to change without notice.

Appendix:

Figures

Figure 1	325LA Specifications
Figure 2	Front and Rear View
Figure 3	Gain Test Set-Up
Figure 4	Harmonic Test Set-Up
Figure 5	Block Diagram

Figure 1:**325LA Specification:**

Frequency Coverage:	250 kHz to 150 MHz
Gain:	50 dB
Gain Variation:	±1.5 dB
Class A Linear Output:	25 Watts P1dB
Saturated Power Output:	50 Watts
Harmonic Distortion:	All harmonics more than 23 dB below main signal at 20W output; lower at reduced power output.
Drive Source Requirements	Any signal generator, function generator, or oscillator capable of 1 mW of output into 50 Ω
Input/Output Impedance: Input VSWR: Output VSWR:	50Ω 1.5:1 Maximum 2:1 Maximum
Power Requirements:	100 – 240 VAC 47-63Hz
Power Output Display:	Forward and Reverse power in Watts; with an accuracy of 5%.
Noise Figure:	10 dB Maximum
Typical 3rd Order Intercept Point:	+53dBm
Stability:	Continuous operation into any load or source impedance.
Protection:	Unit will withstand a +13dBm input signal (IV RMS) for all output load conditions, including short and open circuit loads.
Front Panel Controls:	AC Power On/Off
Front Panel Display:	LCD backlit display
Front Panel Connections:	RF Input RF Output
Operating Temperature:	0° to 45° C
Cooling System	Forced air
Size:	7.5" H x 9.5" W x 12.5" D 19.05 x 23.13 x 31.75 cm.
Weight:	18 lbs (8.1 kg)
Input Connector:	Type BNC
Output Connector:	Type BNC
Rack Mounting:	19 inch adaptors optional

The material contained in this document is the property of Electronics & Innovation Ltd., it is subject to change without notice.

Figure 2

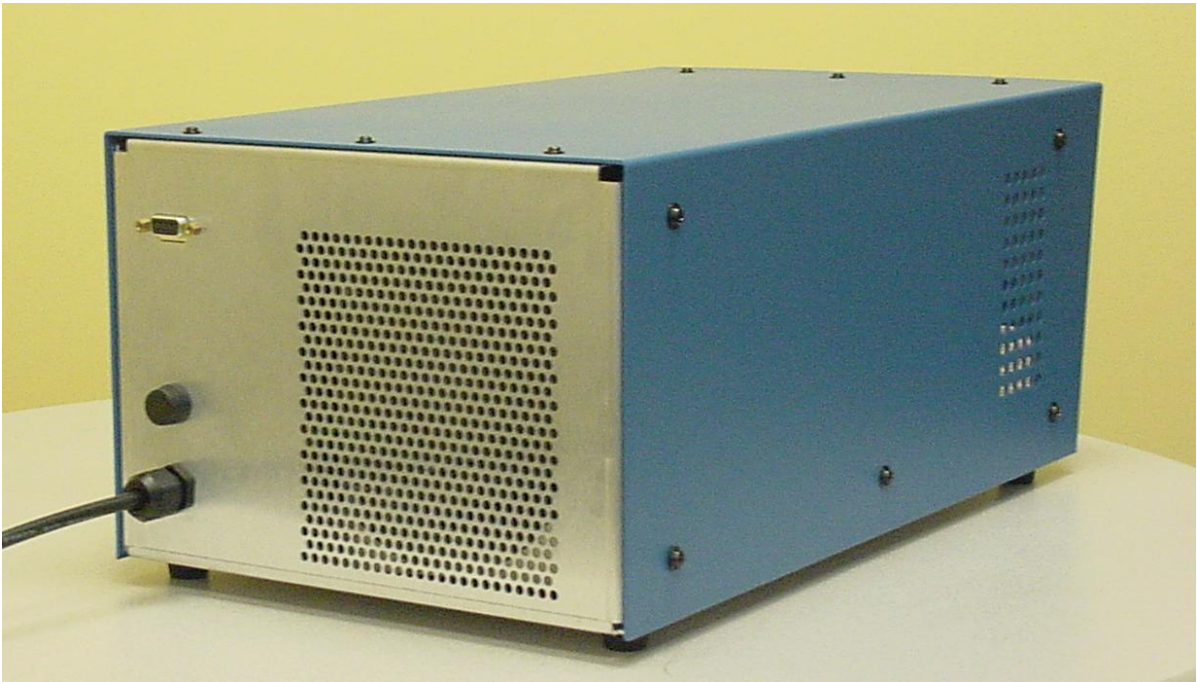

The material contained in this document is the property of Electronics & Innovation Ltd., it is subject to change without notice.

Figure 5

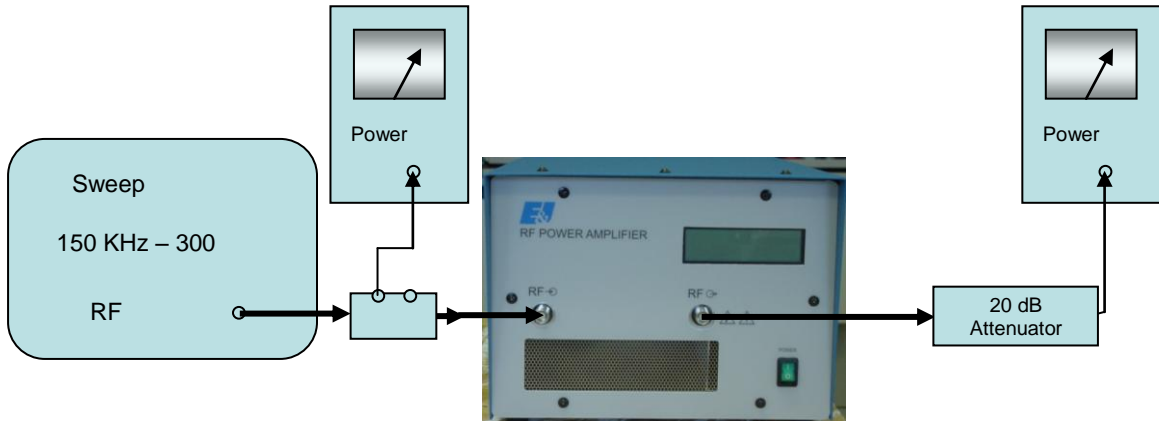
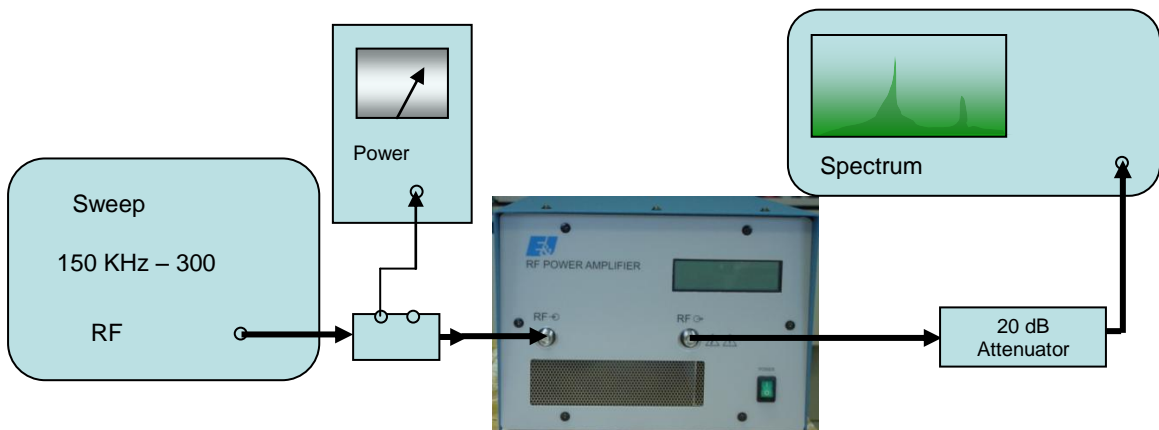
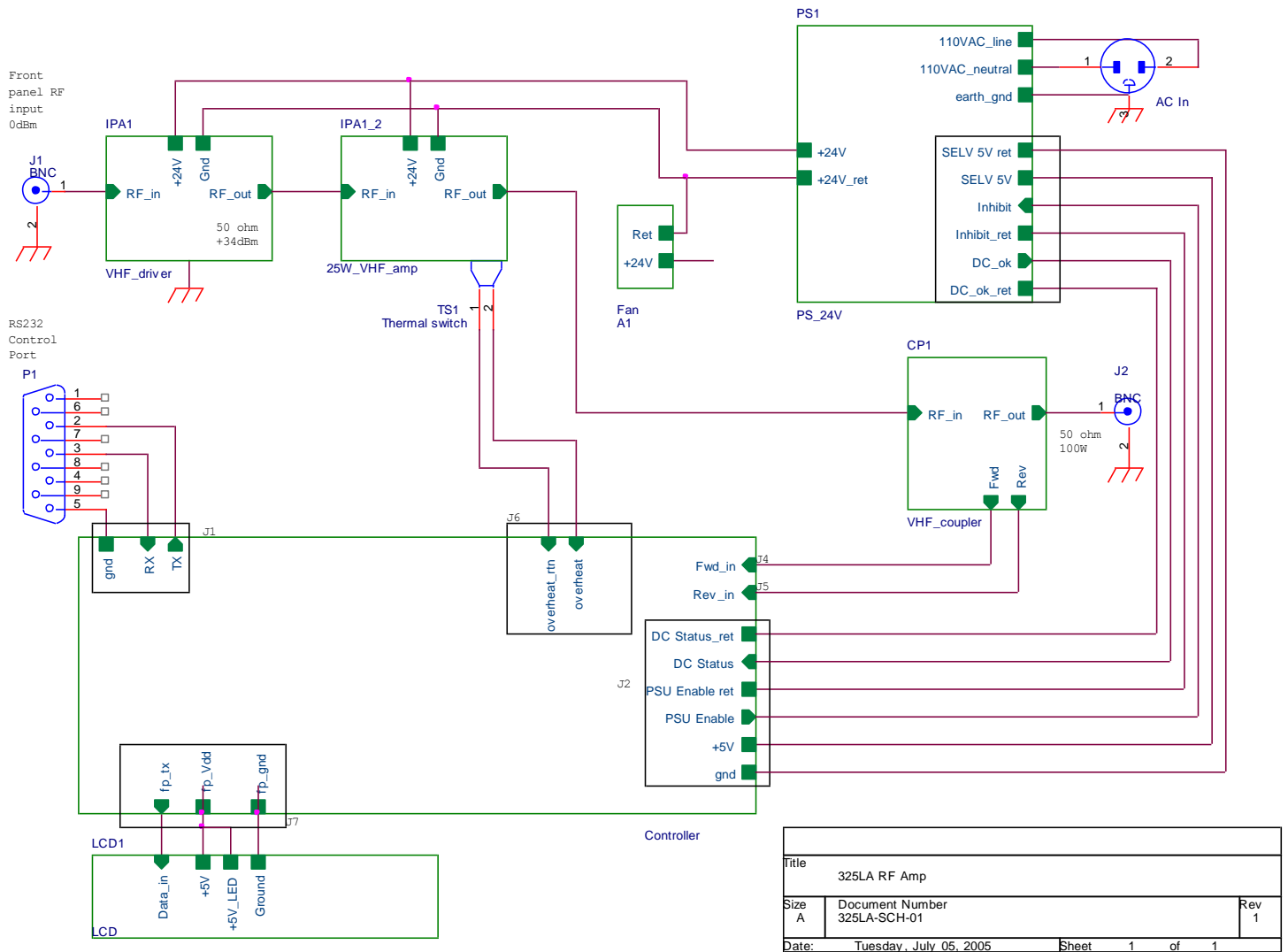

Figure 4



The material contained in this document is the property of Electronics & Innovation Ltd., it is subject to change without notice.

Figure 5



The material contained in this document is the property of Electronics & Innovation Ltd., it is subject to change without notice.

The material contained in this document is the property of Electronics & Innovation Ltd., it is subject to change without notice.