

# **RIGOL**

## **Performance Verification Manual**

### **DP800 Series Programmable Linear DC Power Supply**

**Mar. 2014  
RIGOL Technologies, Inc.**



# Guaranty and Declaration

## Copyright

© 2014 RIGOL Technologies, Inc. All Rights Reserved.

## Trademark Information

**RIGOL** is a registered trademark of RIGOL Technologies, Inc.

## Publication Number

PVH03101-1110

## Notices

- **RIGOL** products are protected by patent law in and outside of P.R.C.
- **RIGOL** reserves the right to modify or change parts of or all the specifications and pricing policies at company's sole decision.
- Information in this publication replaces all previously corresponding material.
- **RIGOL** shall not be liable for losses caused by either incidental or consequential in connection with the furnishing, use or performance of this manual as well as any information contained.
- Any part of this document is forbidden to be copied or photocopied or rearranged without prior written approval of **RIGOL**.

## Product Certification

**RIGOL** guarantees this product conforms to the national and industrial standards in China as well as the ISO9001:2008 standard and the ISO14001:2004 standard. Other international standard conformance certification is in progress.

## Contact Us

If you have any problem or requirement when using our products or this manual, please contact **RIGOL**.

E-mail: [service@rigol.com](mailto:service@rigol.com)

Website: [www.rigol.com](http://www.rigol.com)

## General Safety Summary

Please review the following safety precautions carefully before putting the instrument into operation so as to avoid any personal injury or damage to the instrument and any product connected to it. To prevent potential hazards, please use the instrument only specified by this manual.

### **Use Proper Power Cord.**

Only the power cord designed for the instrument and authorized for use within the local country could be used.

### **Ground the Instrument.**

The instrument is grounded through the Protective Earth lead of the power cord. To avoid electric shock, it is essential to connect the earth terminal of power cord to the Protective Earth terminal before any inputs or outputs.

### **Connect the Probe Correctly.**

If a probe is used, do not connect the ground lead to high voltage since it has the isobaric electric potential as ground.

### **Observe All Terminal Ratings.**

To avoid fire or shock hazard, observe all ratings and markers on the instrument and check your manual for more information about ratings before connecting.

### **Use Proper Overvoltage Protection.**

Make sure that no overvoltage (such as that caused by a thunderstorm) can reach the product, or else the operator might expose to danger of electrical shock.

### **Do Not Operate Without Covers.**

Do not operate the instrument with covers or panels removed.

### **Do Not Insert Anything into the Holes of Fan.**

Do not insert anything into the holes of the fan to avoid damaging the instrument.

### **Use Proper Fuse.**

Please use the specified fuses.

### **Avoid Circuit or Wire Exposure.**

Do not touch exposed junctions and components when the unit is powered.

**Do Not Operate With Suspected Failures.**

If you suspect damage occurs to the instrument, have it inspected by qualified service personnel before further operations. Any maintenance, adjustment or replacement especially to circuits or accessories must be performed by **RIGOL** authorized personnel.

**Keep Well Ventilation.**

Inadequate ventilation may cause increasing of temperature or damages to the device. So please keep well ventilated and inspect the intake and fan regularly.

**Do Not Operate in Wet Conditions.**

In order to avoid short circuiting to the interior of the device or electric shock, please do not operate in a humid environment.

**Do Not Operate in an Explosive Atmosphere.**

In order to avoid damages to the device or personal injuries, it is important to operate the device away from an explosive atmosphere.

**Keep Product Surfaces Clean and Dry.**

To avoid the influence of dust and/or moisture in air, please keep the surface of device clean and dry.

**Electrostatic Prevention.**

Operate in an electrostatic discharge protective area environment to avoid damages induced by static discharges. Always ground both the internal and external conductors of the cable to release static before connecting.

**Proper Use of Battery.**

If a battery is supplied, it must not be exposed to high temperature or in contact with fire. Keep it out of the reach of children. Improper change of battery (note: lithium battery) may cause explosion. Use **RIGOL** specified battery only.

**Handling Safety.**

Please handle with care during transportation to avoid damages to buttons, knob interfaces and other parts on the panels.

**Do Not Provide Power for the Active Load.**

In order to avoid the anti-irrigation current which leads to the power control loop out of control and damage to the powered device, this power supply can only provide power for the pure load without the current output function.

## Allgemeine Sicherheits Informationen

Überprüfen Sie die folgenden Sicherheitshinweise sorgfältig um Personenschäden oder Schäden am Gerät und an damit verbundenen weiteren Geräten zu vermeiden. Zur Vermeidung von Gefahren, nutzen Sie bitte das Gerät nur so, wie in diesem Handbuch angegeben.

### **Um Feuer oder Verletzungen zu vermeiden, verwenden Sie ein ordnungsgemäßes Netzkabel.**

Verwenden Sie für dieses Gerät nur das für ihr Land zugelassene und genehmigte Netzkabel.

### **Erden des Gerätes.**

Das Gerät ist durch den Schutzleiter im Netzkabel geerdet. Um Gefahren durch elektrischen Schlag zu vermeiden, ist es unerlässlich, die Erdung durchzuführen. Erst dann dürfen weitere Ein- oder Ausgänge verbunden werden.

### **Anschluss eines Tastkopfes.**

Die Erdungsklemmen der Sonden sind auf dem gleichen Spannungspegel des Instruments geerdet. Schließen Sie die Erdungsklemmen an keine hohe Spannung an.

### **Beachten Sie alle Anschlüsse.**

Zur Vermeidung von Feuer oder Stromschlag, beachten Sie alle Bemerkungen und Markierungen auf dem Instrument. Befolgen Sie die Bedienungsanleitung für weitere Informationen, bevor Sie weitere Anschlüsse an das Instrument legen.

### **Verwenden Sie einen geeigneten Überspannungsschutz.**

Stellen Sie sicher, daß keinerlei Überspannung (wie z.B. durch Gewitter verursacht) das Gerät erreichen kann. Andernfalls besteht für den Anwender die Gefahr eines Stromschlages.

### **Nicht ohne Abdeckung einschalten.**

Betreiben Sie das Gerät nicht mit entfernten Gehäuse-Abdeckungen.

### **Betreiben Sie das Gerät nicht geöffnet.**

Der Betrieb mit offenen oder entfernten Gehäuseteilen ist nicht zulässig. Nichts in entsprechende Öffnungen stecken (Lüfter z.B.)

### **Passende Sicherung verwenden.**

Setzen Sie nur die spezifikationsgemäßen Sicherungen ein.

### **Vermeiden Sie ungeschützte Verbindungen.**

Berühren Sie keine unisolierten Verbindungen oder Baugruppen, während das Gerät in Betrieb ist.

**Betreiben Sie das Gerät nicht im Fehlerfall.**

Wenn Sie am Gerät einen Defekt vermuten, sorgen Sie dafür, bevor Sie das Gerät wieder betreiben, dass eine Untersuchung durch qualifiziertes Kundendienstpersonal durchgeführt wird. Jedwede Wartung, Einstellarbeiten oder Austausch von Teilen am Gerät, sowie am Zubehör dürfen nur von **RIGOL** autorisiertem Personal durchgeführt werden.

**Belüftung sicherstellen.**

Unzureichende Belüftung kann zu Temperaturanstiegen und somit zu thermischen Schäden am Gerät führen. Stellen Sie deswegen die Belüftung sicher und kontrollieren regelmäßig Lüfter und Belüftungsöffnungen.

**Nicht in feuchter Umgebung betreiben.**

Zur Vermeidung von Kurzschluß im Geräteinneren und Stromschlag betreiben Sie das Gerät bitte niemals in feuchter Umgebung.

**Nicht in explosiver Atmosphäre betreiben.**

Zur Vermeidung von Personen- und Sachschäden ist es unumgänglich, das Gerät ausschließlich fernab jedweder explosiven Atmosphäre zu betreiben.

**Geräteoberflächen sauber und trocken halten.**

Um den Einfluß von Staub und Feuchtigkeit aus der Luft auszuschließen, halten Sie bitte die Geräteoberflächen sauber und trocken.

**Schutz gegen elektrostatische Entladung (ESD).**

Sorgen Sie für eine elektrostatisch geschützte Umgebung, um somit Schäden und Funktionsstörungen durch ESD zu vermeiden. Erden Sie vor dem Anschluß immer Innen- und Außenleiter der Verbindungsleitung, um statische Aufladung zu entladen.

**Die richtige Verwendung des Akku.**

Wenn eine Batterie verwendet wird, vermeiden Sie hohe Temperaturen bzw. Feuer ausgesetzt werden. Bewahren Sie es außerhalb der Reichweite von Kindern auf. Unsachgemäße Änderung der Batterie (Anmerkung: Lithium-Batterie) kann zu einer Explosion führen. Verwenden Sie nur von RIGOL angegebene Akkus.

**Sicherer Transport.**

Transportieren Sie das Gerät sorgfältig (Verpackung!), um Schäden an Bedienelementen, Anschlüssen und anderen Teilen zu vermeiden.

**Vermeiden Sie das Einprägen von Strom und Spannung an den Testklemmen.**

Das DP800 Power Supply kann hierdurch zerstört werden, keine aktive Last. Das DP800 kann nur Strom und Spannungen liefern.

# Document Overview

DP800 series is a high-performance programmable DC power supply. This manual introduces the performance verification test methods of DP800 series. The performance verification test mainly verifies whether DP800 series programmable linear DC power supply can work normally and is within specifications.

## Main topics of this manual

### Chapter 1 Test Overview

This chapter introduces the test preparations, the recommended test devices, the test precautions as well as the test result record and so on.

### Chapter 2 Constant Voltage Tests

This chapter introduces the specification test methods of DP800 under constant voltage (CV) mode.

### Chapter 3 Constant Current Tests

This chapter introduces the specification test methods of DP800 under constant current (CC) mode.

### Appendix

Provide the test result record forms and the performance specifications of all models of DP800 series programmable linear DC power supply.

## Content Conventions in this Manual

DP800 series programmable linear DC power supply includes the following models. Unless specified otherwise in this manual, DP831A is taken as an example to illustrate the performance verification test methods of DP800 series.

| Model        | Channel | Output Voltage/Current              |
|--------------|---------|-------------------------------------|
| DP831A       | 3       | 8V/5A, 30V/2A, -30V/2A              |
| DP832A/DP832 | 3       | 30V/3A, 30V/3A, 5V/3A               |
| DP821A       | 2       | 60V/1A, 8V/10A                      |
| DP811A       | 1       | 20V/10A (Range 1), 40V/5A (Range 2) |



# Contents

|   |            |
|---|------------|
| <b>Guaranty and Declaration .....</b>                 | <b>I</b>   |
| <b>General Safety Summary .....</b>                   | <b>II</b>  |
| <b>Allgemeine Sicherheits Informationen.....</b>      | <b>IV</b>  |
| <b>Document Overview.....</b>                         | <b>VI</b>  |
| <b>Chapter 1 Test Overview .....</b>                  | <b>1-1</b> |
| Test Preparations.....                                | 1-2        |
| Voltage and Current Values .....                      | 1-4        |
| Recommended Test Devices .....                        | 1-5        |
| Test Precautions.....                                 | 1-6        |
| Test Result Record.....                               | 1-6        |
| <b>Chapter 2 Constant Voltage Tests .....</b>         | <b>2-1</b> |
| Preparations .....                                    | 2-2        |
| CV Load Regulation Rate (CV Load Effect) .....        | 2-4        |
| CV Linear Regulation Rate (CV Source Effect).....     | 2-7        |
| CV Ripple and Noise .....                             | 2-11       |
| Transient Response Time .....                         | 2-16       |
| CV Programming and Readback Accuracy .....            | 2-20       |
| <b>Chapter 3 Constant Current Tests.....</b>          | <b>3-1</b> |
| Preparations .....                                    | 3-2        |
| CC Load Regulation Rate (CC Load Effect) .....        | 3-4        |
| CC Linear Regulation Rate (CC Source Effect).....     | 3-7        |
| CC Ripple and Noise (Normal Mode).....                | 3-11       |
| CC Programming and Readback Accuracy .....            | 3-14       |
| <b>Appendix.....</b>                                  | <b>1</b>   |
| Appendix A: Test Result Record Forms.....             | 1          |
| DP831A Performance Verification Test Record Form..... | 1          |
| DP832A Performance Verification Test Record Form..... | 5          |
| DP832 Performance Verification Test Record Form ..... | 9          |
| DP821A Performance Verification Test Record Form..... | 13         |
| DP811A Performance Verification Test Record Form..... | 17         |
| Appendix B: Specifications .....                      | 21         |



# Chapter 1 Test Overview

Topics of this chapter:

- Test Preparations
- Voltage and Current Values
- Recommended Test Devices
- Test Precautions
- Test Result Record

## Test Preparations

You need to finish the following preparations before performing the performance verification test.

1. Perform self-test to make sure that the instrument can work normally.

Connect the instrument to AC power supply using the power cord provided with the accessories. Press the power switch key at the front panel; the instrument starts and performs self-test. You can press **Utility** → **Test/Cal** after power-on to examine the self-test information (including the top board, bottom board, fan and temperature). If the self-test fails, please turn off and then turn on the instrument to perform the self-test again and examine the self-test information. If the self-test still fails, please contact **RIGOL**. Make sure that the reason that results in the self-test failure are found and solved. Perform the performance verification test only after the instrument passes the self-test.

### Notes:

- Before connecting the power, make sure that the setting of the voltage selector at the rear panel of the power supply matches the AC power supply to be connected and the fuse currently installed matches the input voltage. The input voltages supported by DP800 series and the matching fuses are as shown in the table below.

| DP831A/DP821A       |  |
|---------------------|--|
| 100                 | 100Vac ± 10%, 50Hz to 60Hz, T5A fuse                     |
| 115                 | 115Vac ± 10%, 50Hz to 60Hz, T5A fuse                     |
| 230                 | 230Vac ± 10% (maximum 250Vac), 50Hz to 60Hz, T2.5A fuse  |
| DP832A/DP832/DP811A |  |
| 100                 | 100Vac ± 10%, 50Hz to 60Hz, T6.3A fuse                   |
| 115                 | 115Vac ± 10%, 50Hz to 60Hz, T6.3A fuse                   |
| 230                 | 230Vac ± 10% (maximum 250Vac), 50Hz to 60Hz, T3.15A fuse |

**Note:** The upper limit of the input voltage supported by DP800 series is 250Vac.

- Before performing the self-test, make sure that there is no connection at the front and rear panel terminals of the power supply.
2. Make sure that the power supply is within the calibration period (1 year). If calibration is required, please contact **RIGOL**.
  3. Run the instrument for at least 30 minutes.

4. Make sure that the environment temperature is between 20°C and 30°C and the relative humidity is less than 80%.
5. The test connecting wires used should be as short as possible. For the channels that support the Sense function, please short-circuit the (S+) and (+) terminals, (S-) and (-) terminals (as shown in Figure 2-2 or Figure 3-2) of the channels respectively and turn on the Sense function of the corresponding channel before performing the test.

**Note:**

The tests introduced in this manual should be performed by professionals. During the tests, there might be dangerous voltage at the output terminals of the power supply as well as certain test devices.

## Voltage and Current Values

During the test, you need to set the voltage and current of the output channels (output ranges) of the power supply to specified values. The rated output values and maximum output values of the voltage and current of each channel of various models of DP800 series are listed in Table 1-1.

Table 1-1 Voltage and Current Values of the Channels (Ranges) of DP800 Series

| Channel (Range)     | Rated Output Voltage | Max Output Voltage | Rated Output Current | Max Output Current |
|---------------------|----------------------|--------------------|----------------------|--------------------|
| <b>DP831A</b>       |                      |                    |                      |                    |
| CH1                 | 8V                   | 8.4V               | 5A                   | 5.3A               |
| CH2                 | 30V                  | 32V                | 2A                   | 2.1A               |
| CH3                 | -30V                 | -32V               | 2A                   | 2.1A               |
| <b>DP832A/DP832</b> |                      |                    |                      |                    |
| CH1                 | 30V                  | 32V                | 3A                   | 3.2A               |
| CH2                 | 30V                  | 32V                | 3A                   | 3.2A               |
| CH3                 | 5V                   | 5.3V               | 3A                   | 3.2A               |
| <b>DP821A</b>       |                      |                    |                      |                    |
| CH1                 | 60V                  | 63V                | 1A                   | 1.05A              |
| CH2                 | 8V                   | 8.4V               | 10A                  | 10.5A              |
| <b>DP811A</b>       |                      |                    |                      |                    |
| Range1              | 20V                  | 21V                | 10A                  | 10.5A              |
| Range2              | 40V                  | 42V                | 5A                   | 5.3A               |

## Recommended Test Devices

It is recommended that you use the test devices listed in the table below or other test devices whose performance specifications satisfy the "Performance Requirement" listed in the table below to test the performance specifications of the DP800 series.

Table 1-2 Recommended Test Devices

| Device                          | Performance Requirement  | Recommended Instrument  | Use  |
|---------------------------------|--|-------------------------|--|
| Digital Oscilloscope            | Bandwidth: $\geq 20\text{MHz}$<br>Minimum Vertical Scale: $\leq 2\text{mV/div}$<br>Bandwidth Limit: $\leq 20\text{MHz}$  | <b>RIGOL</b><br>DS1102E | Measure ripple and noise, transient response time  |
| Digital Multimeter              | Readout Resolution: $6\frac{1}{2}$   | <b>RIGOL</b> DM3068     | Measure dc voltage   |
| RMS Voltmeter                   | Sensitivity: $1\text{mV}$<br>Bandwidth: $\geq 10\text{MHz}$  |                         | Measure rms ripple and noise   |
| Electronic Load                 | Voltage Range: $80\text{Vdc}$<br>Current Range: $60\text{A dc}$<br>Maximum Power: $300\text{W}$<br>Dynamic frequency: $1\text{kHz}$  | Chroma 63103A           | Measure load regulation rate, linear regulation rate, transient response time                                    |
| AC Power Supply                 | Regulation Rate: $>1\%$  | Chroma 61602            | —  |
| Resistive Load $R_L$            | $0.8\Omega$ ( $200\text{W}$ )<br>$1.6\Omega$ ( $100\text{W}$ )<br>$2\Omega$ ( $400\text{W}$ )<br>$8\Omega$ ( $400\text{W}$ )<br>$10\Omega$ ( $200\text{W}$ )<br>$15\Omega$ ( $200\text{W}$ )<br>$60\Omega$ ( $200\text{W}$ ) | —                       | Measure ripple and noise   |
| Current Sampling Resistor $R_M$ | $0.022\Omega$<br>( $5\text{W}$ , temperature drift: $10\text{ppm}$ )   | —                       | Measure load regulation rate, linear regulation rate, programming accuracy and readback accuracy                 |
| Multimeter Test Probe           | —  | —                       | —  |
| USB Cable                       | USB Device to USB Host, for connecting the power supply and PC   | —                       | —  |
| Short Circuit Device (2)        | —  | —                       | Short-circuit the (S+) and (+) terminals, (S-) and (-) terminals of the channel that supports the Sense function |

## Test Precautions

The output terminal of the power supply is as shown in Figure 1-1. The output terminal is a metal conductor with certain contact resistance ( $\Delta r$ ) and when the output current of the power supply is  $I$ , the voltage of this terminal is  $V_e = \Delta r \times I$ . Therefore, during the test process, the voltage test point is always located at A to reduce the error caused by the terminal voltage as far as possible. Besides, the contact resistance between this terminal and the power output wire/the voltage feedback wire inside the instrument chassis can also cause error (about 2mV, called  $U_{\text{offset}}$ ).

When testing the load regulation rate, voltage peak-peak value and transient response time, the test devices are connected to the output terminal via A and the load resistor is connected to the output terminal via B.

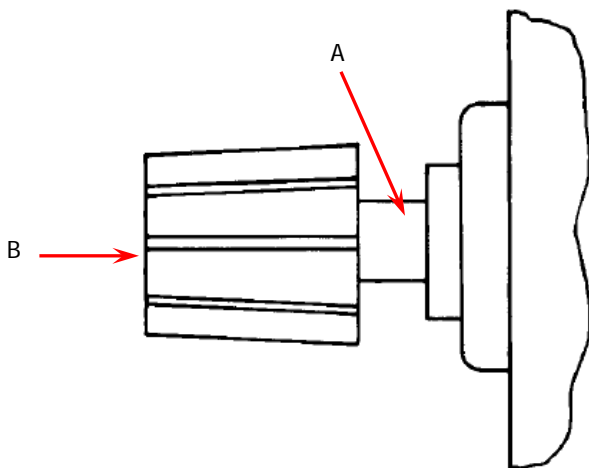

Figure 1-1 Output Terminal

During the test, please pay attention to shield the effect of the environmental space radiation noise on the test effectively.

## Test Result Record

Record and keep the test results of each test item. The test result record forms, which provide all the test items and the corresponding performance specification limits as well as spaces for users to record the test results, of all models of DP800 series programmable linear DC power supply are provided in “**Appendix A: Test Result Record Forms**” of this manual.



**Tip:**

It is recommended that you photocopy the desired test result record form before each test. During the test process, record the test results on the copies so that the forms can be used repeatedly.



## Chapter 2 Constant Voltage Tests

Topics of this chapter:

- Preparations
- CV Load Regulation Rate (CV Load Effect)
- CV Linear Regulation Rate (CV Source Effect)
- CV Ripple and Noise
- Transient Response Time
- CV Programming and Readback Accuracy

# Preparations

When the power supply is in CV state, the main parameters to be tested include CV load regulation rate, CV linear regulation rate, CV ripple and noise, transient response time, CV programming and readback accuracy.

Before performing the tests, select the appropriate voltage via the “voltage selector” at the rear panel of the power supply according to the AC line voltage of the country (230V is taken as an example in all the tests in this manual). Under normal temperature (about 25°C), make connections according to Figure 2-1 or Figure 2-2 using the devices recommended in “**Recommended Test Devices**”. During the test process, please set the voltage of the AC power supply according to the voltage selected of the “voltage selector” at the rear panel of the power supply.

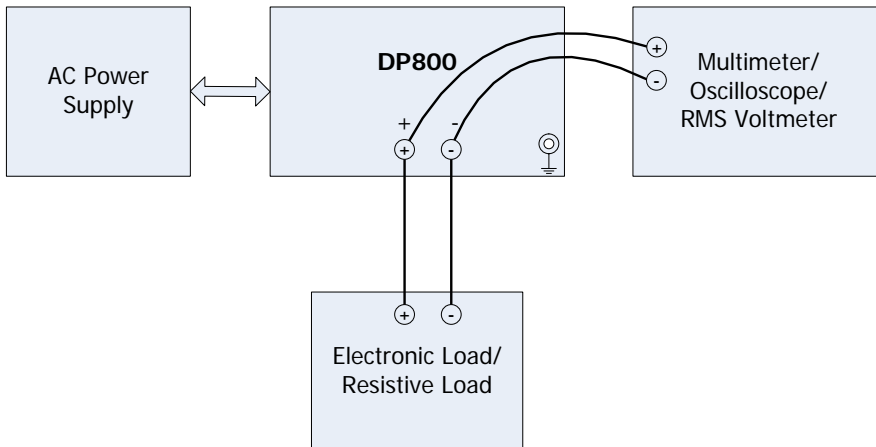

Figure 2-1 CV Test Connections

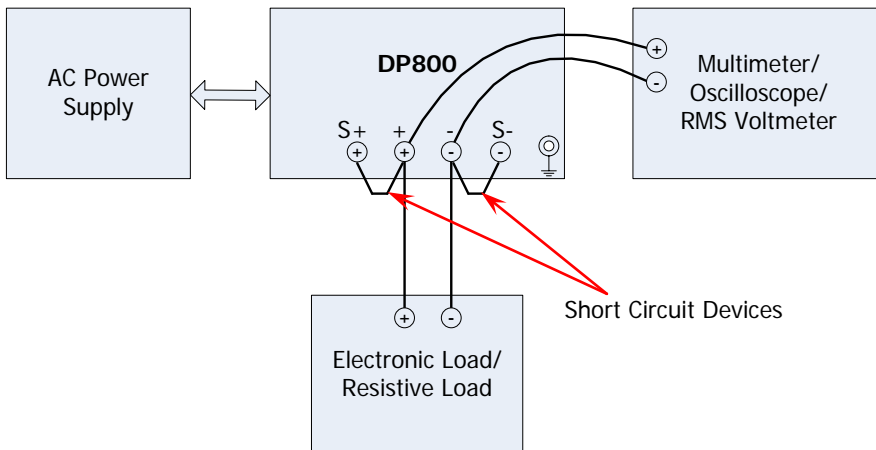

Figure 2-2 CV Test Connections (Sense)

**Note:**

During the CV tests, make connections according to Figure 2-1 for the normal channels (namely the channels that do not support the Sense function) of the DP800 series power supply. For the channels that support the Sense function (CH2 of DP821A and DP811A), make connections according to Figure 2-2 (note to short-circuit the (S+) and (+) terminals, (S-) and (-) terminals of the channel respectively) and turn on the Sense function of the channel during the test process to measure the specifications under Sense mode.

## CV Load Regulation Rate (CV Load Effect)

CV load regulation rate refers to the relation between the variation of the output voltage (caused by the load effect) and the rated output voltage when the power supply is under CV output mode.

DP831A is taken as an example to test the CV load regulation rate of DP800 series in the following section.

**Note:** During the actual test, please select the corresponding test record form according to the model of the DP800 power supply under test to set the corresponding parameters, record and calculate the corresponding specifications.

### Specification:

| Load Regulation Rate, $\pm$ (Output Percentage+Offset) |            |
|--|------------|
| Voltage  | <0.01%+2mV |

### Test Procedures:

1. Turn off DP800. Connect DP800, AC power supply, electronic load and multimeter according to Figure 2-1. Both the electronic load and multimeter are connected with the channel output terminals of DP800; please refer to “**Test Precautions**” for the connection method. Here, CH1 is taken as an example and the connection method is also applicable to CH2 and CH3.
2. Turn on the AC power supply; set its voltage to 230V and frequency to 50Hz.

**Note:** The voltage setting of the AC power supply in this step should be in accordance with the value selected by the voltage selector at the rear panel of DP800.

3. Turn on DP800 and press the channel selecting key at the front panel to select CH1 as the channel to be tested. Set the voltage and current of the channel under test according to Table 2-1. Then, press the **On/Off** key corresponding to the channel under test to enable the output of the channel.
4. Turn on the electronic load. Adjust the current of the electronic load to 0A or do not connect any load device (no load).
5. Turn on the digital multimeter; select DC voltage measurement function and set the range to “Auto”. Make sure that the power supply is in CV mode. Read and record the reading ( $U_0$ ) of the multimeter.
6. Set the electronic load to work in CC mode and adjust the current of the electronic load to the rated output current (please refer to Table 1-1) of the

channel (range) under test. Make sure that the power supply is in CV mode. Read and record the reading ( $U_1$ ) of the multimeter.

7. Calculate the voltage variation (namely the CV load effect,  $|U_1-U_0|$ ) and compare it with the specified specification in Table 2-1.
8. Press the **On/Off** key corresponding to the channel under test at the front channel to disable the output of the channel under test.
9. Repeat steps 1 to 8 to test the CV load regulation rates of CH2 and CH3 until finishing the CV load regulation rate tests of all channels.

### Notes:

- For the single channel model with multiple ranges of DP800 series (DP811A), please first select a range and set the corresponding parameters of this range in step 3 and then perform steps 4 to 8 to test the CV load regulation rate of this range. Then, repeat steps 3 to 8 to test the CV load regulation rate of the other range.
- For the channels that support the Sense function of DP800 series, please connect DP800, AC power supply, electronic load and multimeter according to Figure 2-2 and turn on the Sense function of the channel after selecting the current channel in step 3.

### Test Record Forms:

Table 2-1 DP831A CV Load Regulation Rate Test Record Form

| Channel            |             | CH1 (8V/5A) | CH2 (30V/2A) | CH3 (-30V/2A) |
|--------------------|-------------|-------------|--------------|---------------|
| Specification      |             | <2.8mV      | <5mV         | <5mV          |
| DP831A Setting     | Voltage     | 8V          | 30V          | -30V          |
|                    | Current     | 5.3A        | 2.1A         | 2.1A          |
| Measurement Result | $U_0$       |             |              |               |
|                    | $U_1$       |             |              |               |
|                    | $ U_1-U_0 $ |             |              |               |

Table 2-2 DP832A CV Load Regulation Rate Test Record Form

| Channel            |             | CH1 (30V/3A) | CH2 (30V/3A) | CH3 (5V/3A) |
|--------------------|-------------|--------------|--------------|-------------|
| Specification      |             | <5mV         | <5mV         | <2.5mV      |
| DP832A Setting     | Voltage     | 30V          | 30V          | 5V          |
|                    | Current     | 3.2A         | 3.2A         | 3.2A        |
| Measurement Result | $U_0$       |              |              |             |
|                    | $U_1$       |              |              |             |
|                    | $ U_1-U_0 $ |              |              |             |

Table 2-3 DP832 CV Load Regulation Rate Test Record Form

| Channel            |             | CH1 (30V/3A) | CH2 (30V/3A) | CH3 (5V/3A) |
|--------------------|-------------|--------------|--------------|-------------|
| Specification      |             | <5mV         | <5mV         | <2.5mV      |
| DP832 Setting      | Voltage     | 30V          | 30V          | 5V          |
|                    | Current     | 3.2A         | 3.2A         | 3.2A        |
| Measurement Result | $U_0$       |              |              |             |
|                    | $U_1$       |              |              |             |
|                    | $ U_1-U_0 $ |              |              |             |

Table 2-4 DP821A CV Load Regulation Rate Test Record Form

| Channel            |             | CH1 (60V/1A) | CH2 (8V/10A) |
|--------------------|-------------|--------------|--------------|
| Specification      |             | <8mV         | <2.8mV       |
| DP821A Setting     | Voltage     | 60V          | 8V           |
|                    | Current     | 1.05A        | 10.5A        |
| Measurement Result | $U_0$       |              |              |
|                    | $U_1$       |              |              |
|                    | $ U_1-U_0 $ |              |              |

Table 2-5 DP811A CV Load Regulation Rate Test Record Form

| Range              |             | Range1 (20V/10A) | Range2 (40V/5A) |
|--------------------|-------------|------------------|-----------------|
| Specification      |             | <4mV             | <6mV            |
| DP811A Setting     | Voltage     | 20V              | 40V             |
|                    | Current     | 10.5A            | 5.3A            |
| Measurement Result | $U_0$       |                  |                 |
|                    | $U_1$       |                  |                 |
|                    | $ U_1-U_0 $ |                  |                 |



## CV Linear Regulation Rate (CV Source Effect)

CV linear regulation rate refers to the relation between the variation of the output voltage (caused by the variation of the input power) and the rated output voltage when the power supply is under CV output mode.

DP831A is taken as an example to test the CV linear regulation rate of DP800 series in the following section.

**Note:** During the actual test, please select the corresponding test record form according to the model of the DP800 power supply under test to set the corresponding parameters, record and calculate the corresponding specifications.

### Specification:

| Linear Regulation Rate, ± (Output Percentage+Offset) |            |
|--|------------|
| Voltage  | <0.01%+2mV |

### Test Procedures:

1. Turn off DP800. Connect DP800, AC power supply, electronic load and multimeter according to Figure 2-1. Both the electronic load and multimeter are connected with the channel output terminals of DP800; please refer to “**Test Precautions**” for the connection method. Here, CH1 is taken as an example and the connection method is also applicable to CH2 and CH3.

**Note:** Set the voltage selector (100, 115 or 230) at the rear panel of DP800 according to your need and make sure that the fuse currently installed matches the actual input voltage (please refer to Table 2-6). As the test methods when selecting different voltages are the same, 230V is taken as an example for illustration.

2. Turn on the AC power supply; set its voltage to 230V and frequency to 50Hz.

**Note:** The voltage setting of the AC power supply in this step should be in accordance with the value selected by the voltage selector at the rear panel of DP800.

3. Turn on DP800 and press the channel selecting key at the front panel to select CH1 as the channel to be tested. Set the voltage and current of the channel under test according to Table 2-7. Then, press the **On/Off** key corresponding to the channel under test to enable the output of the channel.
4. Turn on the electronic load; set the electronic load to work in CC mode and adjust the current of the electronic load to the rated output current (please refer to Table 1-1) of the channel (range) under test.

5. Turn on the digital multimeter; select DC voltage measurement function and set the range to "Auto". Make sure that the power supply is in CV mode. Read and record the reading ( $U_0$ ) of the multimeter.
6. Adjust the AC power supply to undervoltage state (namely the amplitude reduces by 10%, refer to Table 2-6); read and record the reading ( $U_1$ ) of the multimeter. Adjust the AC power supply to overvoltage state (namely the amplitude increases by 10%, refer to Table 2-6); read and record the reading ( $U_2$ ) of the multimeter.  
**Note:** The upper limit of the overvoltage of DP800 series is 250Vac.
7. Calculate the voltage variations (namely the CV source effect,  $|U_1-U_0|$  and  $|U_2-U_0|$ ) and compare them with the specified specifications in Table 2-7.
8. Press the **On/Off** key corresponding to the channel under test at the front channel to disable the output of the channel under test.
9. Repeat steps 1 to 8 to test the CV linear regulation rates of CH2 and CH3 until finishing the CV linear regulation rate tests of all channels.

**Notes:**

- For the single channel model with multiple ranges of DP800 series (DP811A), please first select a range and set the corresponding parameters of this range in step 3 and then perform step 4 to step 8 to test the CV linear regulation rate of this range. Then, repeat step 3 to step 8 to test the CV linear regulation rate of the other range.
- For the channels that support the Sense function of DP800 series, please connect DP800, AC power supply, electronic load and multimeter according to Figure 2-2 and turn on the Sense function of the channel after selecting the current channel in step 3.

Table 2-6 AC Power Supply Setting Form

| DP831A/DP821A       |       |       |        |
|---------------------|-------|-------|--------|
| Voltage Selector    | 100   | 115   | 230    |
| Fuse                | T5A   | T5A   | T2.5A  |
| Undervoltage (Vac)  | 90    | 103   | 207    |
| Overvoltage (Vac)   | 110   | 127   | 250    |
| DP832A/DP832/DP811A |       |       |        |
| Voltage Selector    | 100   | 115   | 230    |
| Fuse                | T6.3A | T6.3A | T3.15A |
| Undervoltage (Vac)  | 90    | 103   | 207    |
| Overvoltage (Vac)   | 110   | 127   | 250    |

## Test Record Forms:

Table 2-7 DP831A CV Linear Regulation Rate Test Record Form

| Channel               |             | CH1 (8V/5A) | CH2 (30V/2A) | CH3 (-30V/2A) |
|-----------------------|-------------|-------------|--------------|---------------|
| Specification         |             | <2.8mV      | <5mV         | <5mV          |
| DP831A<br>Setting     | Voltage     | 8V          | 30V          | -30V          |
|                       | Current     | 5.3A        | 2.1A         | 2.1A          |
| Measurement<br>Result | $U_0$       |             |              |               |
|                       | $U_1$       |             |              |               |
|                       | $U_2$       |             |              |               |
|                       | $ U_1-U_0 $ |             |              |               |
|                       | $ U_2-U_0 $ |             |              |               |

Table 2-8 DP832A CV Linear Regulation Rate Test Record Form

| Channel               |             | CH1 (30V/3A) | CH2 (30V/3A) | CH3 (5V/3A) |
|-----------------------|-------------|--------------|--------------|-------------|
| Specification         |             | <5mV         | <5mV         | <2.5mV      |
| DP832A<br>Setting     | Voltage     | 30V          | 30V          | 5V          |
|                       | Current     | 3.2A         | 3.2A         | 3.2A        |
| Measurement<br>Result | $U_0$       |              |              |             |
|                       | $U_1$       |              |              |             |
|                       | $U_2$       |              |              |             |
|                       | $ U_1-U_0 $ |              |              |             |
|                       | $ U_2-U_0 $ |              |              |             |

Table 2-9 DP832 CV Linear Regulation Rate Test Record Form

| Channel               |             | CH1 (30V/3A) | CH2 (30V/3A) | CH3 (5V/3A) |
|-----------------------|-------------|--------------|--------------|-------------|
| Specification         |             | <5mV         | <5mV         | <2.5mV      |
| DP832<br>Setting      | Voltage     | 30V          | 30V          | 5V          |
|                       | Current     | 3.2A         | 3.2A         | 3.2A        |
| Measurement<br>Result | $U_0$       |              |              |             |
|                       | $U_1$       |              |              |             |
|                       | $U_2$       |              |              |             |
|                       | $ U_1-U_0 $ |              |              |             |
|                       | $ U_2-U_0 $ |              |              |             |

Table 2-10 DP821A CV Linear Regulation Rate Test Record Form

| Channel            |             | CH1 (60V/1A) | CH2 (8V/10A) |
|--------------------|-------------|--------------|--------------|
| Specification      |             | <8mV         | <2.8mV       |
| DP821A Setting     | Voltage     | 60V          | 8V           |
|                    | Current     | 1.05A        | 10.5A        |
| Measurement Result | $U_0$       |              |              |
|                    | $U_1$       |              |              |
|                    | $U_2$       |              |              |
|                    | $ U_1-U_0 $ |              |              |
|                    | $ U_2-U_0 $ |              |              |

Table 2-11 DP811A CV Linear Regulation Rate Test Record Form

| Range              |             | Range1 (20V/10A) | Range2 (40V/5A) |
|--------------------|-------------|------------------|-----------------|
| Specification      |             | <4mV             | <6mV            |
| DP811A Setting     | Voltage     | 20V              | 40V             |
|                    | Current     | 10.5A            | 5.3A            |
| Measurement Result | $U_0$       |                  |                 |
|                    | $U_1$       |                  |                 |
|                    | $U_2$       |                  |                 |
|                    | $ U_1-U_0 $ |                  |                 |
|                    | $ U_2-U_0 $ |                  |                 |

## CV Ripple and Noise

When the power supply is working in CV mode, the combination of the periodic and random deviations (PARD) when outputting DC voltage is equivalent to superimposing a residual AC voltage on the DC output voltage. This residual AC voltage, namely the ripple and noise (usually, ripple is periodic offset while noise is random offset), can be expressed in RMS or peak-to-peak value form.

DP831A is taken as an example to test the CV ripple and noise of DP800 series in the following section.

**Note:** During the actual test, please select the corresponding test record form according to the model of the DP800 power supply under test to set and select the corresponding parameters, record and calculate the corresponding specifications.

### Specification:

| Ripple and Noise (20Hz-20MHz) |                       |
|-------------------------------|-----------------------|
| Normal Mode Voltage           | <350 $\mu$ Vrms/2mVpp |

### Test Procedures:

1. Turn off DP800. Connect DP800, AC power supply, resistive load and oscilloscope according to Figure 2-1. Both the resistive load and oscilloscope are connected with the channel output terminals of DP800; please refer to “**Test Precautions**” for the connection method. Here, CH1 is taken as an example and the connection method is also applicable to CH2 and CH3.

### Notes:

- Do not connect the negative terminal of the output terminal of the channel to be tested to the shielding ground; otherwise, a ground loop would be formed. In Figure 2-3, the connection in figure A forms a ground loop while figure B shows the correct connection.

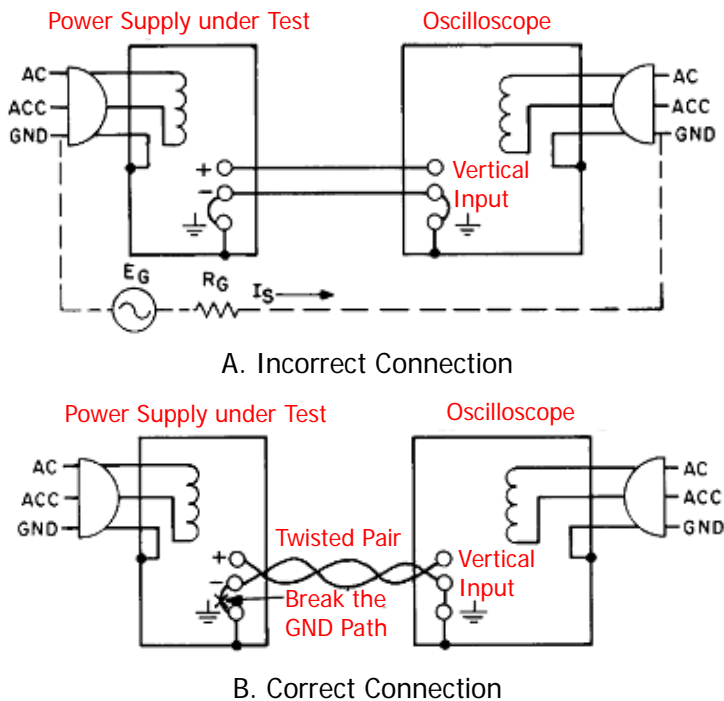

Figure 2-3 Peak-peak Value Measurement Connections

- Please use resistive load instead of electronic load to avoid the effect on the noise measurement of the power supply caused by the electronic load noise. Please refer to Table 2-12 for the resistance of the resistive load.
  - Connect the positive terminal of the oscilloscope probe to the positive terminal (+) of the output terminals of the channel under test of the power supply and connect the ground terminal of the oscilloscope probe to the negative terminal (-) of the output terminals of the channel under test of the power supply. During the test, please ensure the effective contact. Note that you are recommended to use ground spring as ground wire so as to minimize the current coupling area between the probe tip and the ground wire and to minimize the space radiation interference.
2. Turn on the AC power supply; set its voltage to 230V and frequency to 50Hz.

**Note:** The voltage setting of the AC power supply in this step should be in accordance with the value selected by the voltage selector at the rear panel of DP800.

3. Turn on DP800 and press the channel selecting key at the front panel to select CH1 as the channel to be tested. Set the voltage and current of the channel under test according to Table 2-12. Then, press the **On/Off** key corresponding to the channel under test to enable the output of the channel.

4. Turn on the oscilloscope and set the oscilloscope parameters. Set the timebase to 5ms/div, the vertical scale to 2mV, the sample mode to peak detect, the coupling mode to AC and the trigger source to AC Line. The input impedance is 1M $\Omega$ . Enable the 20MHz bandwidth limit and then enable the peak-peak value measurement function of the oscilloscope. Make sure that the power supply is in CV mode. Read and record the peak-peak value ( $V_{pp}$ ) measured by the oscilloscope and compare it with the specified specification in Table 2-12.
5. Turn off the oscilloscope and disconnect the connection between DP800 and the oscilloscope. Connect DP800, AC power supply, resistive load and RMS voltmeter according to Figure 2-1. Turn on the RMS voltmeter and select the AC voltage random measurement mode (SETACV RNDM). Make sure that the power supply is in CV mode. Read and record the RMS value ( $V_{rms}$ ) measured by the RMS voltmeter and compare it with the specified specification in Table 2-12.

**Note:** The measurement wires of the RMS voltmeter should be twisted together to minimize the effect of the space radiation noise on the test as much as possible.

6. Press the **On/Off** key corresponding to the channel under test at the front channel to disable the output of the channel under test.
7. Repeat steps 1 to 6 to test the CV ripple and noise of CH2 and CH3 until finishing the CV ripple and noise tests of all channels.

**Notes:**

- During the CV ripple and noise test, please pay attention to shield the effect of the environmental space radiation noise on the test effectively.
- For the single channel model with multiple ranges of DP800 series (DP811A), please first select a range and set the corresponding parameters of this range in step 3 and then perform step 4 to step 6 to test the CV ripple and noise of this range. Then, repeat step 3 to step 6 to test the CV ripple and noise of the other range.
- For the channels that support the Sense function of DP800 series, please connect DP800, AC power supply, resistive load and oscilloscope (RMS voltmeter) according to Figure 2-2 and turn on the Sense function of the channel after selecting the current channel in step 3.

## Test Record Forms:

Table 2-12 DP831A CV Ripple and Noise Test Record Form

| Channel              |                       | CH1 (8V/5A)           | CH2 (30V/2A) | CH3 (-30V/2A) |
|----------------------|-----------------------|-----------------------|--------------|---------------|
| Specification        |                       | <350 $\mu$ Vrms/3mVpp |              |               |
| Resistive Load $R_L$ |                       | 1.6 $\Omega$          | 15 $\Omega$  | 15 $\Omega$   |
| DP831A Setting       | Voltage               | 8V                    | 30V          | -30V          |
|                      | Current               | 5.3A                  | 2.1A         | 2.1A          |
| Measurement Result   | Peak-peak value (Vpp) |                       |              |               |
|                      | RMS value (Vrms)      |                       |              |               |

Table 2-13 DP832A CV Ripple and Noise Test Record Form

| Channel              |                       | CH1 (30V/3A)          | CH2 (30V/3A) | CH3 (5V/3A)  |
|----------------------|-----------------------|-----------------------|--------------|--------------|
| Specification        |                       | <350 $\mu$ Vrms/3mVpp |              |              |
| Resistive Load $R_L$ |                       | 10 $\Omega$           | 10 $\Omega$  | 1.6 $\Omega$ |
| DP832A Setting       | Voltage               | 30V                   | 30V          | 5V           |
|                      | Current               | 3.2A                  | 3.2A         | 3.2A         |
| Measurement Result   | Peak-peak value (Vpp) |                       |              |              |
|                      | RMS value (Vrms)      |                       |              |              |

Table 2-14 DP832 CV Ripple and Noise Test Record Form

| Channel              |                       | CH1 (30V/3A)          | CH2 (30V/3A) | CH3 (5V/3A)  |
|----------------------|-----------------------|-----------------------|--------------|--------------|
| Specification        |                       | <350 $\mu$ Vrms/3mVpp |              |              |
| Resistive Load $R_L$ |                       | 10 $\Omega$           | 10 $\Omega$  | 1.6 $\Omega$ |
| DP832 Setting        | Voltage               | 30V                   | 30V          | 5V           |
|                      | Current               | 3.2A                  | 3.2A         | 3.2A         |
| Measurement Result   | Peak-peak value (Vpp) |                       |              |              |
|                      | RMS value (Vrms)      |                       |              |              |



Table 2-15 DP821A CV Ripple and Noise Test Record Form

| Channel              |                       | CH1 (60V/1A)          | CH2 (8V/10A) |
|----------------------|-----------------------|-----------------------|--------------|
| Specification        |                       | <350 $\mu$ Vrms/3mVpp |              |
| Resistive Load $R_L$ |                       | 60 $\Omega$           | 0.8 $\Omega$ |
| DP821A Setting       | Voltage               | 60V                   | 8V           |
|                      | Current               | 1.05A                 | 10.5A        |
| Measurement Result   | Peak-peak value (Vpp) |                       |              |
|                      | RMS value (Vrms)      |                       |              |

Table 2-16 DP811A CV Ripple and Noise Test Record Form

| Range                |                       | Range1 (20V/10A)      | Range2 (40V/5A) |
|----------------------|-----------------------|-----------------------|-----------------|
| Specification        |                       | <350 $\mu$ Vrms/3mVpp |                 |
| Resistive Load $R_L$ |                       | 2 $\Omega$            | 8 $\Omega$      |
| DP811A Setting       | Voltage               | 20V                   | 40V             |
|                      | Current               | 10.5A                 | 5.3A            |
| Measurement Result   | Peak-peak value (Vpp) |                       |                 |
|                      | RMS value (Vrms)      |                       |                 |

## Transient Response Time

Transient response time refers to the time required for the output voltage of the power supply to recover to within 15mV following a transient variation in the load current (50% transient variation, namely the output current changes from full load to half load or vice versa). As shown in Figure 2-4,  $t$  is the transient response time.

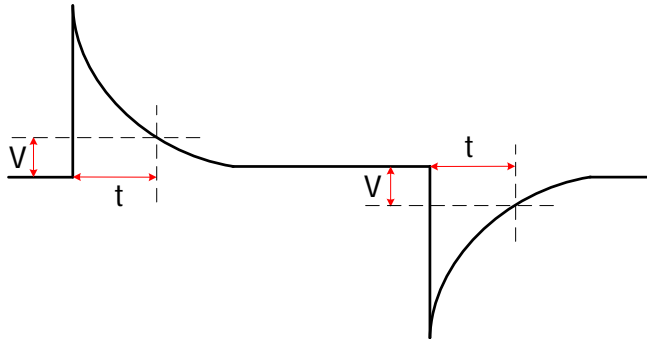

Figure 2-4 Transient Response Time

DP831A is taken as an example to test the transient response time of DP800 series in the following section.

**Note:** During the actual test, please select the corresponding test record form according to the model of the DP800 power supply under test to set the corresponding parameters, record and calculate the corresponding specifications.

### Specification:

| Transient Response Time  |
|--|
| Less than 50 $\mu$ s for output voltage to recover to within 15 mV following a change in output current from full load to half load or vice versa. |

### Test Procedures:

1. Turn off DP800. Connect DP800, AC power supply, electronic load and oscilloscope according to Figure 2-1. Both the electronic load and oscilloscope are connected with the channel output terminals of DP800; please refer to “**Test Precautions**” for the connection method. Here, CH1 is taken as an example and the connection method is also applicable to CH2 and CH3
2. Turn on the AC power supply; set its voltage to 230V and frequency to 50Hz.

**Note:** The voltage setting of the AC power supply in this step should be in accordance with the value selected by the voltage selector at the rear panel of DP800.

3. Turn on DP800 and press the channel selecting key at the front panel to select CH1 as the channel to be tested. Set the voltage and current of the channel under test according to Table 2-17. Then, press the **On/Off** key corresponding to the channel under test to enable the output of the channel.
4. Turn on the electronic load and set the electronic load parameters. Select the CC dynamic response mode (CCDH mode); set CCDH1 to the rated current value of the channel (range) under test, CCDH2 to the current value of the channel (range) under test with half load (for the CCDH1 and CCDH2 values, please refer to Table 2-17), CCDHT1 and CCDHT2 to 500 $\mu$ s (namely 1kHz frequency and 50% duty cycle), the rising edge time and falling edge time to 250mA/ $\mu$ s. Turn on the electronic load and make sure that the programmable electronic load is in CC mode.
5. Turn on the oscilloscope and set the oscilloscope parameters. Set the coupling mode to AC, the trigger source to AC Line and enable the 20MHz bandwidth limit. Enable the cursor measurement function and measure the transient response time (namely  $\Delta X$ ) displayed on the screen of the oscilloscope, as shown in the figure below, and compare it with the specified specification in Table 2-17.

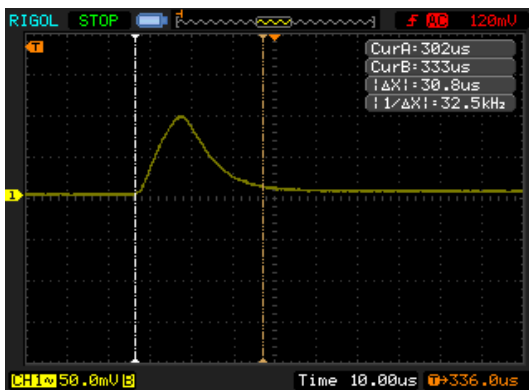

6. Press the **On/Off** key corresponding to the channel under test at the front channel to disable the output of the channel under test.
7. Repeat steps 1 to 6 to test the transient response time of CH2 and CH3 until finishing the transient response time tests of all channels.

**Notes:**

- For the single channel model with multiple ranges of DP800 series (DP811A), please first select a range and set the corresponding parameters of this range in step 3 and then perform step 4 to step 6 to test the transient response time of this range. Then, repeat step 3 to step 6 to test the transient response time of the other range.
- For the channels that support the Sense function of DP800 series, please connect DP800, AC power supply, electronic load and oscilloscope according to Figure 2-2 and turn on the Sense function of the channel after selecting the current channel in step 3.

**Test Record Forms:**

Table 2-17 DP831A Transient Response Time Test Record Form

| Channel                         |         | CH1 (8V/5A) | CH2 (30V/2A) | CH3 (-30V/2A) |
|---------------------------------|---------|-------------|--------------|---------------|
| Specification                   |         | <50μs       |              |               |
| DP831A Setting                  | Voltage | 8V          | 30V          | -30V          |
|                                 | Current | 5.3A        | 2.1A         | 2.1A          |
| Electronic Load Current Setting | CCDH1   | 5A          | 2A           | 2A            |
|                                 | CCDH2   | 2.5A        | 1A           | 1A            |
| Measurement Result              | t       |             |              |               |

Table 2-18 DP832A Transient Response Time Test Record Form

| Channel                         |         | CH1 (30V/3A) | CH2 (30V/3A) | CH3 (5V/3A) |
|---------------------------------|---------|--------------|--------------|-------------|
| Specification                   |         | <50μs        |              |             |
| DP832A Setting                  | Voltage | 30V          | 30V          | 5V          |
|                                 | Current | 3.2A         | 3.2A         | 3.2A        |
| Electronic Load Current Setting | CCDH1   | 3A           | 3A           | 3A          |
|                                 | CCDH2   | 1.5A         | 1.5A         | 1.5A        |
| Measurement Result              | t       |              |              |             |

Table 2-19 DP832 Transient Response Time Test Record Form

| Channel                         |         | CH1 (30V/3A) | CH2 (30V/3A) | CH3 (5V/3A) |
|---------------------------------|---------|--------------|--------------|-------------|
| Specification                   |         | <50 $\mu$ s  |              |             |
| DP832 Setting                   | Voltage | 30V          | 30V          | 5V          |
|                                 | Current | 3.2A         | 3.2A         | 3.2A        |
| Electronic Load Current Setting | CCDH1   | 3A           | 3A           | 3A          |
|                                 | CCDH2   | 1.5A         | 1.5A         | 1.5A        |
| Measurement Result              | t       |              |              |             |

Table 2-20 DP821A Transient Response Time Test Record Form

| Channel                         |         | CH1 (60V/1A) | CH2 (8V/10A) |
|---------------------------------|---------|--------------|--------------|
| Specification                   |         | <50 $\mu$ s  |              |
| DP821A Setting                  | Voltage | 60V          | 8V           |
|                                 | Current | 1.05A        | 10.5A        |
| Electronic Load Current Setting | CCDH1   | 1A           | 10A          |
|                                 | CCDH2   | 0.5A         | 5A           |
| Measurement Result              | t       |              |              |

Table 2-21 DP811A Transient Response Time Test Record Form

| Range                           |         | Range1 (20V/10A) | Range2 (40V/5A) |
|---------------------------------|---------|------------------|-----------------|
| Specification                   |         | <50 $\mu$ s      |                 |
| DP811A Setting                  | Voltage | 20V              | 40V             |
|                                 | Current | 10.5A            | 5.3A            |
| Electronic Load Current Setting | CCDH1   | 10A              | 5A              |
|                                 | CCDH2   | 5A               | 2.5A            |
| Measurement Result              | t       |                  |                 |

## CV Programming and Readback Accuracy

CV programming accuracy refers to the error between the voltage setting of the channel and the actual output voltage value when the power supply is in CV mode; CV readback accuracy refers to the error between the actual output voltage value and the readback voltage value when the power supply is in CV mode.

DP831A is taken as an example to test the CV programming and readback accuracy of DP800 series in the following section.

**Note:** During the actual test, please select the corresponding test record form according to the model of the DP800 power supply under test to set the corresponding parameters, record and calculate the corresponding specifications.

### Specification:

| Annual Accuracy <sup>[1]</sup> (25°C ± 5°C) ± (Output Percentage + Offset) |     |             |            |
|--|-----|-------------|------------|
| Channel  |     | Programming | Readback   |
| DP831A   | CH1 | 0.1%+5mV    | 0.1%+5mV   |
|  | CH2 | 0.05%+20mV  | 0.05%+10mV |
|  | CH3 | 0.05%+20mV  | 0.05%+10mV |
| DP832A   | CH1 | 0.05%+20mV  | 0.05%+10mV |
|  | CH2 | 0.05%+20mV  | 0.05%+10mV |
|  | CH3 | 0.1%+5mV    | 0.1%+5mV   |
| DP832  | CH1 | 0.05%+10mV  | 0.05%+5mV  |
|  | CH2 | 0.05%+10mV  | 0.05%+5mV  |
|  | CH3 | 0.05%+10mV  | 0.05%+5mV  |
| DP821A   | CH1 | 0.1%+25mV   | 0.1%+25mV  |
|  | CH2 | 0.05%+10mV  | 0.05%+5mV  |
| DP811A   | CH1 | 0.05%+10mV  | 0.05%+10mV |

**Note**<sup>[1]</sup>: The accuracy parameters are acquired via calibration under 25°C after 1-hour warm-up.

### Test Procedures:

1. Turn off DP800. Connect DP800, AC power supply and multimeter according to Figure 2-1. The multimeter is connected with the channel output terminals of DP800; please refer to “**Test Precautions**” for the connection method. Here, CH1 is taken as an example and the connection method is also applicable to CH2 and CH3. Then, connect the power supply with PC (take the connection via USB cable as an example) via the remote interfaces (USB, GPIB, LAN).
2. Turn on the AC power supply; set its voltage to 230V and frequency to 50Hz.

**Note:** The voltage setting of the AC power supply in this step should be in

accordance with the value selected by the voltage selector at the rear panel of DP800.

3. Measure the CV programming and readback accuracy (take CH1 as an example in this place) when the output voltage is 0V.

- 1) Turn on DP800. Send the following commands via the remote interface to select the channel to be tested (namely the current channel), set the voltage and current of this channel (please refer to Table 2-22) as well as enable the output of this channel.

```
:APPL CH1,0,5.3      /*Select CH1 as the current channel and set the
                       voltage and current of this channel to 0V and
                       5.3A respectively*/
:OUTP CH1,ON        /*Enable the output of CH1*/
```

### Notes:

- The above commands are only applicable to the multi-channel models of DP800. You can also send the `:INST:NSEL 1` (or `:INST CH1`) command to select CH1 as the current channel, the `:SOUR1:VOLT 0` command to set the voltage of CH1 to 0V and the `:SOUR1:CURREN 5.3` command to set the current of CH1 to 5.3A.
  - For the single channel model with multiple ranges of DP800 series (DP811A), you can send the `:OUTP:RANG P20V` (or `:OUTP:RANG LOW`, or `:VOLT:RANG P20V`, or `:VOLT:RANG LOW`) command to select Range1 as the current range and then send the `:VOLT 0` command to set the voltage of the channel to 0V and the `:CURREN 10.5` command to set the current of the channel to 10.5A.
- 2) Turn on the digital multimeter; select DC voltage measurement function and set the range to "Auto". Make sure that the power supply is in CV mode. Read and record the reading ( $U_1$ ) of the multimeter.
  - 3) Send the `:MEAS:VOLT? CH1` command via the remote interface; read and record the returned voltage value  $U_2$  of the query command.
  - 4) Calculate the CV programming accuracy ( $|U_1-0|$ ) and the CV readback accuracy ( $|U_2-U_1|$ ). Compare them with the specified specifications in Table 2-22.
4. Measure the CV programming and readback accuracy (take CH1 as an example in this place) when the output voltage is the rated output value.
    - 1) Send the following command via the remote interface to select the channel to be tested (namely the current channel) and set the voltage and current

of this channel (please refer to Table 2-22).

```
:APPL CH1,8,5.3      /*Select CH1 as the current channel and set the
                       voltage and current of this channel to 8V and
                       5.3A respectively*/
```

**Notes:**

- The above command is only applicable to the multi-channel models of DP800. You can also send the `:INST:NSEL 1` (or `:INST CH1`) command to select CH1 as the current channel, the `:SOUR1:VOLT 8` command to set the voltage of CH1 to 8V and the `:SOUR1:CURREN 5.3` command to set the current of CH1 to 5.3A.
  - For the single channel model with multiple ranges of DP800 series (DP811A), you can send the `:OUTP:RANG P20V` (or `:OUTP:RANG LOW`, or `:VOLT:RANG P20V`, or `:VOLT:RANG LOW`) command to select Range1 as the current range and then send the `:VOLT 20` command to set the voltage of the channel to 20V and the `:CURR 10.5` command to set the current of the channel to 10.5A.
- 2) Make sure that the power supply is in CV mode. Read and record the reading ( $U_3$ ) of the multimeter.
  - 3) Send the `:MEAS:VOLT? CH1` command via the remote interface; read and record the returned voltage value  $U_4$  of the query command.
  - 4) Calculate the CV programming accuracy ( $|U_3 - U_R|$ ) and the CV readback accuracy ( $|U_4 - U_3|$ ). Compare them with the specified specifications in Table 2-22. Wherein,  $U_R$  is the rated output voltage of the channel under test.
  - 5) Send the following command via the remote interface to disable the output of the channel under test.

```
:OUTP CH1,OFF      /*Disable the output of CH1*/
```

5. Repeat steps 1 to 4 to test the CV programming and readback accuracy of CH2 and CH3 until finishing the CV programming and readback accuracy tests of all channels.

**Note:** For the multi-channel models of DP800 series, please replace the "CH1" in the remote commands in steps 3 and 4 with "CH2" or "CH3" to select and set the corresponding channel.



**Notes:**

- For the single channel model with multiple ranges of DP800 series (DP811A), please first select Range1, set the parameters of Range1 and measure the CV programming and readback accuracy of this range in steps 3 and 4. Then, repeat step 3 and step 4 to test the CV programming and readback accuracy of Range2 (please replace the "P20V" or "LOW" in the remote commands in steps 3 and 4 with "P40V" or "HIGH").
- For the channels that support the Sense function of DP800 series, please connect DP800, AC power supply and multimeter according to Figure 2-2 and send the remote command (DP821A: :OUTP:SENS CH2,ON; DP811A: :OUTP:SENS CH1,ON) to turn on the Sense function of the channel under test before turning on the output of the channel under test in step 3.

**Test Record Forms:**

Table 2-22 DP831A CV Programming and Readback Accuracy Test Record Form

| Channel  |  | CH1 (8V/5A) | CH2 (30V/2A) | CH3 (-30V/2A) |
|--|--|-------------|--------------|---------------|
| Specification  | Programming  | <13mV       | <35mV        | <35mV         |
|  | Readback   | <13mV       | <25mV        | <25mV         |
| <b>The output voltage is 0</b>                           |  |             |              |               |
| DP831A Setting   | Voltage  | 0V          | 0V           | 0V            |
|  | Current  | 5.3A        | 2.1A         | 2.1A          |
| Measurement Result                                       | U <sub>1</sub>   |             |              |               |
|  | U <sub>2</sub>   |             |              |               |
|  | Programming:<br> U <sub>1</sub> -0                             |             |              |               |
|  | Readback:<br> U <sub>2</sub> -U <sub>1</sub>                   |             |              |               |
| <b>The output voltage is U<sub>R</sub><sup>[1]</sup></b> |  |             |              |               |
| DP831A Setting   | Voltage  | 8V          | 30V          | -30V          |
|  | Current  | 5.3A        | 2.1A         | 2.1A          |
| Measurement Result                                       | U <sub>3</sub>   |             |              |               |
|  | U <sub>4</sub>   |             |              |               |
|  | Programming:<br> U <sub>3</sub> -U <sub>R</sub> <sup>[1]</sup> |             |              |               |
|  | Readback:<br> U <sub>4</sub> -U <sub>3</sub>                   |             |              |               |

**Note<sup>[1]</sup>:** The rated voltage of the specified channel.

Table 2-23 DP832A CV Programming and Readback Accuracy Test Record Form

| Channel  |  | CH1 (30V/3A) | CH2 (30V/3A) | CH3 (5V/3A) |
|--|--|--------------|--------------|-------------|
| Specification  | Programming  | <35mV        | <35mV        | <10mV       |
|  | Readback   | <25mV        | <25mV        | <10mV       |
| <b>The output voltage is 0</b>                           |  |              |              |             |
| DP832A Setting   | Voltage  | 0V           | 0V           | 0V          |
|  | Current  | 3.2A         | 3.2A         | 3.2A        |
| Measurement Result                                       | U <sub>1</sub>   |              |              |             |
|  | U <sub>2</sub>   |              |              |             |
|  | Programming:<br> U <sub>1</sub> -0                             |              |              |             |
|  | Readback:<br> U <sub>2</sub> -U <sub>1</sub>                   |              |              |             |
| <b>The output voltage is U<sub>R</sub><sup>[1]</sup></b> |  |              |              |             |
| DP832A Setting   | Voltage  | 30V          | 30V          | 5V          |
|  | Current  | 3.2A         | 3.2A         | 3.2A        |
| Measurement Result                                       | U <sub>3</sub>   |              |              |             |
|  | U <sub>4</sub>   |              |              |             |
|  | Programming:<br> U <sub>3</sub> -U <sub>R</sub> <sup>[1]</sup> |              |              |             |
|  | Readback:<br> U <sub>4</sub> -U <sub>3</sub>                   |              |              |             |

Note<sup>[1]</sup>: The rated voltage of the specified channel.

Table 2-24 DP832 CV Programming and Readback Accuracy Test Record Form

| Channel   |                                   | CH1 (30V/3A) | CH2 (30V/3A) | CH3 (5V/3A) |
|---|-----------------------------------|--------------|--------------|-------------|
| Specification                                       | Programming                       | <25mV        | <25mV        | <12.5mV     |
|   | Readback                          | <20mV        | <20mV        | <7.5mV      |
| <b>The output voltage is 0</b>                      |                                   |              |              |             |
| DP832 Setting                                       | Voltage                           | 0V           | 0V           | 0V          |
|   | Current                           | 3.2A         | 3.2A         | 3.2A        |
| Measurement Result                                  | $U_1$                             |              |              |             |
|   | $U_2$                             |              |              |             |
|   | Programming:<br>$ U_1-0 $         |              |              |             |
|   | Readback:<br>$ U_2-U_1 $          |              |              |             |
| <b>The output voltage is <math>U_R^{[1]}</math></b> |                                   |              |              |             |
| DP832 Setting                                       | Voltage                           | 30V          | 30V          | 5V          |
|   | Current                           | 3.2A         | 3.2A         | 3.2A        |
| Measurement Result                                  | $U_3$                             |              |              |             |
|   | $U_4$                             |              |              |             |
|   | Programming:<br>$ U_3-U_R^{[1]} $ |              |              |             |
|   | Readback:<br>$ U_4-U_3 $          |              |              |             |

**Note<sup>[1]</sup>**: The rated voltage of the specified channel.

Table 2-25 DP821A CV Programming and Readback Accuracy Test Record Form

| Channel   |                                   | CH1 (60V/1A) | CH2 (8V/10A) |
|---|-----------------------------------|--------------|--------------|
| Specification                                       | Programming                       | <85mV        | <14mV        |
|   | Readback                          | <85mV        | <9mV         |
| <b>The output voltage is 0</b>                      |                                   |              |              |
| DP821A Setting                                      | Voltage                           | 0V           | 0V           |
|   | Current                           | 1.05A        | 10.5A        |
| Measurement Result                                  | $U_1$                             |              |              |
|   | $U_2$                             |              |              |
|   | Programming:<br>$ U_1-0 $         |              |              |
|   | Readback:<br>$ U_2-U_1 $          |              |              |
| <b>The output voltage is <math>U_R^{[1]}</math></b> |                                   |              |              |
| DP821A Setting                                      | Voltage                           | 60V          | 8V           |
|   | Current                           | 1.05A        | 10.5A        |
| Measurement Result                                  | $U_1$                             |              |              |
|   | $U_2$                             |              |              |
|   | Programming:<br>$ U_3-U_R^{[1]} $ |              |              |
|   | Readback:<br>$ U_4-U_3 $          |              |              |

Note<sup>[1]</sup>: The rated voltage of the specified channel.

Table 2-26 DP811A CV Programming and Readback Accuracy Test Record Form

| Range   |                                   | Range1 (20V/10A) | Range2 (40V/5A) |
|---|-----------------------------------|------------------|-----------------|
| Specification                                       | Programming                       | <20mV            | <30mV           |
|   | Readback                          | <20mV            | <30mV           |
| <b>The output voltage is 0</b>                      |                                   |                  |                 |
| DP811A Setting                                      | Voltage                           | 0V               | 0V              |
|   | Current                           | 10.5A            | 5.3A            |
| Measurement Result                                  | $U_1$                             |                  |                 |
|   | $U_2$                             |                  |                 |
|   | Programming:<br>$ U_1-0 $         |                  |                 |
|   | Readback:<br>$ U_2-U_1 $          |                  |                 |
| <b>The output voltage is <math>U_R^{[1]}</math></b> |                                   |                  |                 |
| DP811A Setting                                      | Voltage                           | 20V              | 40V             |
|   | Current                           | 10.5A            | 5.3A            |
| Measurement Result                                  | $U_1$                             |                  |                 |
|   | $U_2$                             |                  |                 |
|   | Programming:<br>$ U_3-U_R^{[1]} $ |                  |                 |
|   | Readback:<br>$ U_4-U_3 $          |                  |                 |

Note<sup>[1]</sup>: The rated voltage of the specified range.



## Chapter 3 Constant Current Tests

Topics of this chapter:

- Preparations
- CC Load Regulation Rate (CC Load Effect)
- CC Linear Regulation Rate (CC Source Effect)
- CC Ripple and Noise (Normal Mode)
- CC Programming and Readback Accuracy

## Preparations

When the power supply is in CC mode, the main parameters to be tested include CC load regulation rate, CC linear regulation rate, CC ripple and noise and CC programming and readback accuracy.

Before performing the tests, select the appropriate voltage via the “voltage selector” at the rear panel of the power supply according to the AC line voltage of the country (230V is taken as an example in all the tests in this manual). Under normal temperature (about 25°C), make connections according to Figure 3-1 or Figure 3-2 using the devices recommended in “**Recommended Test Devices**” (for CC ripple and noise test, please connect the desired devices according to Figure 2-1 or Figure 2-2). During the test process, please set the voltage of the AC power supply according to the voltage selected of the “voltage selector” at the rear panel of the power supply.

In CC tests (not including CC ripple and noise test), a current sampling resistor should be connected between the power supply under test and the electronic load serially to convert the current signal under test to voltage signal for the measurement of related parameters.

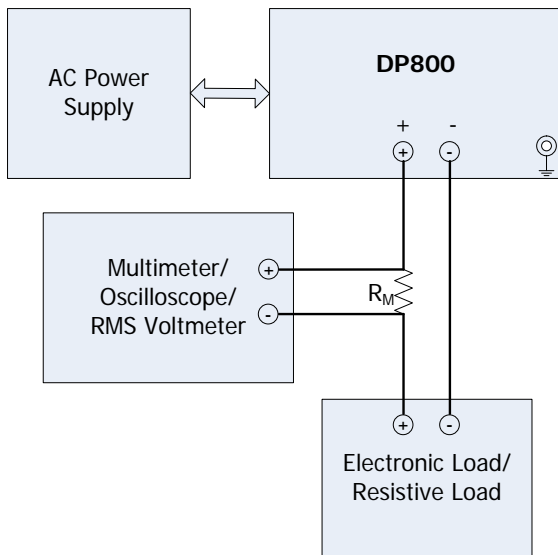

Figure 3-1 CC Test Connections



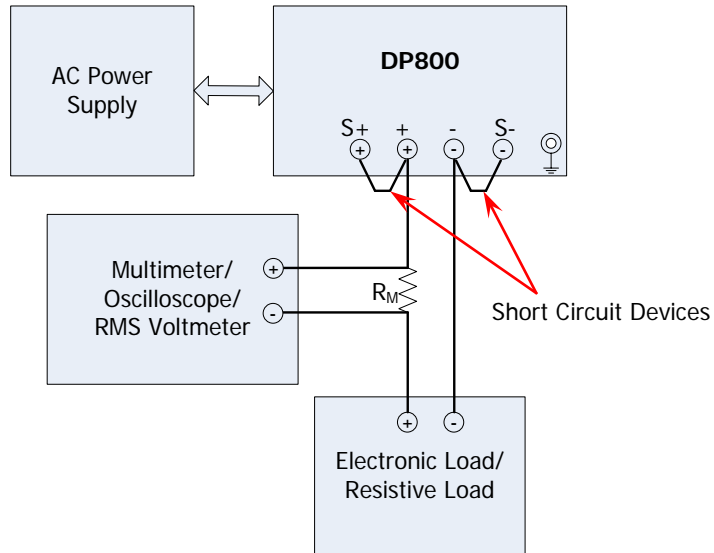

Figure 3-2 CC Test Connections (Sense)

**Notes:**

- During the CC tests, make connections according to Figure 3-1 for the normal channels (namely the channels that do not support the Sense function) of the DP800 series power supply. For the channels that support the Sense function (CH2 of DP821A and DP811A), make connections according to Figure 3-2 (note to short-circuit the (S+) and (+) terminals, (S-) and (-) terminals of the channel respectively) and turn on the Sense function of the channel during the test process to measure the specifications under Sense mode.
- The  $R_M$  in the figures above is a 4-wire current sampling resistor (please select current sampling resistor with suitable resistance according to the test item and the channel to be tested). As shown in Figure 3-3, **C** represents the current measurement terminal and **S** represents the voltage measurement terminal. During the test, please make the correct connections.

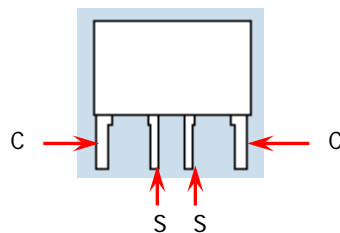

Figure 3-3 4-wire Current Sampling Resistor

## CC Load Regulation Rate (CC Load Effect)

CC load regulation rate refers to the relation between the variation of the output current (caused by the load effect) and the rated output current when the power supply is under CC output mode.

DP831A is taken as an example to test the CC load regulation rate of DP800 series in the following section.

**Note:** During the actual test, please select the corresponding test record form according to the model of the DP800 power supply under test to set the corresponding parameters, record and calculate the corresponding specifications.

### Specification:

| Load Regulation Rate, $\pm$ (Output Percentage+Offset) |                    |
|--|--------------------|
| Current  | <0.01%+250 $\mu$ A |

### Test Procedures:

1. Turn off DP800. Connect DP800, AC power supply, current sampling resistor (the resistance  $R_M$  is 0.022 $\Omega$ ), electronic load and multimeter according to Figure 3-1. Please pay attention to the connection method of the current sampling resistor, electronic load and the channel output terminals of DP800 as well as the connection method of the current sampling resistor and multimeter. Here, CH1 is taken as an example and the connection method is also applicable to CH2 and CH3.

2. Turn on the AC power supply; set its voltage to 230V and frequency to 50Hz.

**Note:** The voltage setting of the AC power supply in this step should be in accordance with the value selected by the voltage selector at the rear panel of DP800.

3. Turn on DP800 and press the channel selecting key at the front panel to select CH1 as the channel to be tested. Set the voltage and current of the channel under test according to Table 3-1. Then, press the **On/Off** key corresponding to the channel under test to enable the output of the channel.

4. Turn on the electronic load. Set the electronic load to short circuit mode. At this point, the channel under test of the power supply is in CC mode.

5. Turn on the digital multimeter; select DC voltage measurement function and set the range to "Auto". Make sure that the power supply is in CC mode. Read and record the reading ( $U_0$ , namely the voltage of the current sampling resistor) of the multimeter.

6. Set the electronic load to work in CV mode and adjust the voltage of the electronic load to the rated output voltage (please refer to Table 1-1) of the channel (range) under test. At this point, the channel under test of the power supply is still in CC mode and is near full load output. Read and record the reading ( $U_1$ ) of the multimeter.
7. Calculate the current variation ( $|U_1/R_M - U_0/R_M|$ ) and compare it with the specified specification in Table 3-1.
8. Press the **On/Off** key corresponding to the channel under test at the front channel to disable the output of the channel under test.
9. Repeat steps 1 to 8 to test the CC load regulation rates of CH2 and CH3 until finishing the CC load regulation rate tests of all channels.

**Notes:**

- For the single channel model with multiple ranges of DP800 series (DP811A), please first select a range and set the corresponding parameters of this range in step 3 and then perform steps 4 to 8 to test the CC load regulation rate of this range. Then, repeat steps 3 to 8 to test the CC load regulation rate of the other range.
- For the channels that support the Sense function of DP800 series, please connect DP800, AC power supply, current sampling resistor, electronic load and multimeter according to Figure 3-2 and turn on the Sense function of the channel after selecting the current channel in step 3.

**Test Record Forms:**

Table 3-1 DP831A CC Load Regulation Rate Test Record Form

| Channel            |                                   | CH1 (8V/5A)  | CH2 (30V/2A) | CH3 (-30V/2A) |
|--------------------|-----------------------------------|--------------|--------------|---------------|
| Specification      |                                   | <750 $\mu$ A | <450 $\mu$ A | <450 $\mu$ A  |
| DP831A Setting     | Voltage                           | 8.4V         | 32V          | -32V          |
|                    | Current                           | 5A           | 2A           | 2A            |
| Measurement Result | $U_0$                             |              |              |               |
|                    | $U_1$                             |              |              |               |
|                    | $ U_1/R_M^{[1]} - U_0/R_M^{[1]} $ |              |              |               |

Note<sup>[1]</sup>:  $R_M=0.022\Omega$ .

Table 3-2 DP832A CC Load Regulation Rate Test Record Form

| Channel            |                                   | CH1 (30V/3A) | CH2 (30V/3A) | CH3 (5V/3A) |
|--------------------|-----------------------------------|--------------|--------------|-------------|
| Specification      |                                   | <550μA       |              |             |
| DP832A Setting     | Voltage                           | 32V          | 32V          | 5.3V        |
|                    | Current                           | 3A           | 3A           | 3A          |
| Measurement Result | U <sub>0</sub>                    |              |              |             |
|                    | U <sub>1</sub>                    |              |              |             |
|                    | $ U_1/R_M^{[1]} - U_0/R_M^{[1]} $ |              |              |             |

Note<sup>[1]</sup>: R<sub>M</sub>=0.022Ω.

Table 3-3 DP832 CC Load Regulation Rate Test Record Form

| Channel            |                                   | CH1 (30V/3A) | CH2 (30V/3A) | CH3 (5V/3A) |
|--------------------|-----------------------------------|--------------|--------------|-------------|
| Specification      |                                   | <550μA       |              |             |
| DP832 Setting      | Voltage                           | 32V          | 32V          | 5.3V        |
|                    | Current                           | 3A           | 3A           | 3A          |
| Measurement Result | U <sub>0</sub>                    |              |              |             |
|                    | U <sub>1</sub>                    |              |              |             |
|                    | $ U_1/R_M^{[1]} - U_0/R_M^{[1]} $ |              |              |             |

Note<sup>[1]</sup>: R<sub>M</sub>=0.022Ω.

Table 3-4 DP821A CC Load Regulation Rate Test Record Form

| Channel            |                                   | CH1 (60V/1A) | CH2 (8V/10A) |
|--------------------|-----------------------------------|--------------|--------------|
| Specification      |                                   | <350μA       | <1.25mA      |
| DP821A Setting     | Voltage                           | 63V          | 8.4V         |
|                    | Current                           | 1A           | 10A          |
| Measurement Result | U <sub>0</sub>                    |              |              |
|                    | U <sub>1</sub>                    |              |              |
|                    | $ U_1/R_M^{[1]} - U_0/R_M^{[1]} $ |              |              |

Note<sup>[1]</sup>: R<sub>M</sub>=0.022Ω.

Table 3-5 DP811A CC Load Regulation Rate Test Record Form

| Range              |                                   | Range1 (20V/10A) | Range2 (40V/5A) |
|--------------------|-----------------------------------|------------------|-----------------|
| Specification      |                                   | <1.25mA          | <750μA          |
| DP811A Setting     | Voltage                           | 21V              | 42V             |
|                    | Current                           | 10A              | 5A              |
| Measurement Result | U <sub>0</sub>                    |                  |                 |
|                    | U <sub>1</sub>                    |                  |                 |
|                    | $ U_1/R_M^{[1]} - U_0/R_M^{[1]} $ |                  |                 |

Note<sup>[1]</sup>: R<sub>M</sub>=0.022Ω.

## CC Linear Regulation Rate (CC Source Effect)

CC linear regulation rate refers to the relation between the variation of the output current (caused by the variation of the input power) and the rated output current when the power supply is under CC output mode.

DP831A is taken as an example to test the CC linear regulation rate of DP800 series in the following section.

**Note:** During the actual test, please select the corresponding test record form according to the model of the DP800 power supply under test to set the corresponding parameters, record and calculate the corresponding specifications.

### Specification:

| Linear Regulation Rate, ± (Output Percentage+Offset) |              |
|--|--------------|
| Current  | <0.01%+250μA |

### Test Procedures:

1. Turn off DP800. Connect DP800, AC power supply, current sampling resistor (the resistance  $R_M$  is  $0.022\Omega$ ), electronic load and multimeter according to Figure 3-1. Please pay attention to the connection method of the current sampling resistor, electronic load and the channel output terminals of DP800 as well as the connection method of the current sampling resistor and multimeter. Here, CH1 is taken as an example and the connection method is also applicable to CH2 and CH3.

**Note:** Set the voltage selector (100, 115 or 230) at the rear panel of DP800 according to your need and make sure that the fuse currently installed matches the actual input voltage (please refer to Table 2-6). As the test methods when selecting different voltages are the same, 230V is taken as an example for illustration.

2. Turn on the AC power supply; set its voltage to 230V and frequency to 50Hz.

**Note:** The voltage setting of the AC power supply in this step should be in accordance with the value selected by the voltage selector at the rear panel of DP800.

3. Turn on DP800 and press the channel selecting key at the front panel to select CH1 as the channel to be tested. Set the voltage and current of the channel under test according to Table 3-6. Then, press the **On/Off** key corresponding to the channel under test to enable the output of the channel.

4. Turn on the electronic load; set the electronic load to work in CV mode and adjust the voltage of the electronic load to the rated output voltage (please refer to Table 1-1) of the channel (range) under test.
5. Turn on the digital multimeter; select DC voltage measurement function and set the range to "Auto". Make sure that the power supply is in CC mode. Read and record the reading ( $U_0$ , namely the voltage of the current sampling resistor) of the multimeter.
6. Adjust the AC power supply to undervoltage state (namely the amplitude reduces by 10%, refer to Table 2-6); read and record the reading ( $U_1$ ) of the multimeter. Adjust the AC power supply to overvoltage state (namely the amplitude increases by 10%, refer to Table 2-6); read and record the reading ( $U_2$ ) of the multimeter.

**Note:** The upper limit of the overvoltage of DP800 series is 250Vac.

7. Calculate the voltage variations (namely the CC source effect,  $|U_1-U_0|/R_M$  and  $|U_2-U_0|/R_M$ ) and compare them with the specified specifications in Table 3-6.
8. Press the **On/Off** key corresponding to the channel under test at the front channel to disable the output of the channel under test.
9. Repeat steps 1 to 8 to test the CC linear regulation rates of CH2 and CH3 until finishing the CC linear regulation rate tests of all channels.

**Notes:**

- For the single channel model with multiple ranges of DP800 series (DP811A), please first select a range and set the corresponding parameters of this range in step 3 and then perform step 4 to step 8 to test the CC linear regulation rate of this range. Then, repeat step 3 to step 8 to test the CC linear regulation rate of the other range.
- For the channels that support the Sense function of DP800 series, please connect DP800, AC power supply, current sampling resistor, electronic load and multimeter according to Figure 3-2 and turn on the Sense function of the channel after selecting the current channel in step 3.

## Test Record Forms:

Table 3-6 DP831A CC Linear Regulation Rate Test Record Form

| Channel            |                       | CH1 (8V/5A)  | CH2 (30V/2A) | CH3 (-30V/2A) |
|--------------------|-----------------------|--------------|--------------|---------------|
| Specification      |                       | <750 $\mu$ A | <450 $\mu$ A | <450 $\mu$ A  |
| DP831A Setting     | Voltage               | 8.4V         | 32V          | -32V          |
|                    | Current               | 5A           | 2A           | 2A            |
| Measurement Result | $U_0$                 |              |              |               |
|                    | $U_1$                 |              |              |               |
|                    | $U_2$                 |              |              |               |
|                    | $ U_1-U_0 /R_M^{[1]}$ |              |              |               |
|                    | $ U_2-U_0 /R_M^{[1]}$ |              |              |               |

Note<sup>[1]</sup>:  $R_M=0.022\Omega$ .

Table 3-7 DP832A CC Linear Regulation Rate Test Record Form

| Channel            |                       | CH1 (30V/3A) | CH2 (30V/3A) | CH3 (5V/3A) |
|--------------------|-----------------------|--------------|--------------|-------------|
| Specification      |                       | <550 $\mu$ A |              |             |
| DP832A Setting     | Voltage               | 32V          | 32V          | 5.3V        |
|                    | Current               | 3A           | 3A           | 3A          |
| Measurement Result | $U_0$                 |              |              |             |
|                    | $U_1$                 |              |              |             |
|                    | $U_2$                 |              |              |             |
|                    | $ U_1-U_0 /R_M^{[1]}$ |              |              |             |
|                    | $ U_2-U_0 /R_M^{[1]}$ |              |              |             |

Note<sup>[1]</sup>:  $R_M=0.022\Omega$ .

Table 3-8 DP832 CC Linear Regulation Rate Test Record Form

| Channel            |                       | CH1 (30V/3A) | CH2 (30V/3A) | CH3 (5V/3A) |
|--------------------|-----------------------|--------------|--------------|-------------|
| Specification      |                       | <550 $\mu$ A |              |             |
| DP832 Setting      | Voltage               | 32V          | 32V          | 5.3V        |
|                    | Current               | 3A           | 3A           | 3A          |
| Measurement Result | $U_0$                 |              |              |             |
|                    | $U_1$                 |              |              |             |
|                    | $U_2$                 |              |              |             |
|                    | $ U_1-U_0 /R_M^{[1]}$ |              |              |             |
|                    | $ U_2-U_0 /R_M^{[1]}$ |              |              |             |

Note<sup>[1]</sup>:  $R_M=0.022\Omega$ .

Table 3-9 DP821A CC Linear Regulation Rate Test Record Form

| Channel            |                       | CH1 (60V/1A) | CH2 (8V/10A) |
|--------------------|-----------------------|--------------|--------------|
| Specification      |                       | <350μA       | <1.25mA      |
| DP821A Setting     | Voltage               | 63V          | 8.4V         |
|                    | Current               | 1A           | 10A          |
| Measurement Result | U <sub>0</sub>        |              |              |
|                    | U <sub>1</sub>        |              |              |
|                    | U <sub>2</sub>        |              |              |
|                    | $ U_1-U_0 /R_M^{[1]}$ |              |              |
|                    | $ U_2-U_0 /R_M^{[1]}$ |              |              |

Note<sup>[1]</sup>: R<sub>M</sub>=0.022Ω.

Table 3-10 DP811A CC Linear Regulation Rate Test Record Form

| Range              |                       | Range1 (20V/10A) | Range2 (40V/5A) |
|--------------------|-----------------------|------------------|-----------------|
| Specification      |                       | <1.25mA          | <750μA          |
| DP811A Setting     | Voltage               | 21V              | 42V             |
|                    | Current               | 10A              | 5A              |
| Measurement Result | U <sub>0</sub>        |                  |                 |
|                    | U <sub>1</sub>        |                  |                 |
|                    | U <sub>2</sub>        |                  |                 |
|                    | $ U_1-U_0 /R_M^{[1]}$ |                  |                 |
|                    | $ U_2-U_0 /R_M^{[1]}$ |                  |                 |

Note<sup>[1]</sup>: R<sub>M</sub>=0.022Ω.



## CC Ripple and Noise (Normal Mode)

When the power supply is working in CC mode, the ripple and noise are usually expressed in RMS value form.

DP831A is taken as an example to test the CC ripple and noise of DP800 series in the following section.

**Note:** During the actual test, please select the corresponding test record form according to the model of the DP800 power supply under test to set the corresponding parameters, record and calculate the corresponding specifications.

### Specification:

| Ripple and Noise (20 Hz to 20 MHz) |         |
|------------------------------------|---------|
| Normal Mode Current                | <2mArms |

### Test Procedures:

1. Turn off DP800. Connect DP800, AC power supply, resistive load and RMS voltmeter according to Figure 2-1. Both the resistive load and RMS voltmeter are connected with the channel output terminals of DP800; please refer to “**Test Precautions**” for the connection method. Here, CH1 is taken as an example and the connection method is also applicable to CH2 and CH3.

#### Note:

- Do not connect the negative terminal of the output terminal of the channel to be tested to the shielding ground; otherwise, a ground loop would be formed. In Figure 2-3, the connection in figure A forms a ground loop while figure B shows the correct connection.
- Please ensure to test the CC ripple and noise of DP800 under full load condition. Refer to Table 3-11 for the resistance of the resistive load.

2. Turn on the AC power supply; set its voltage to 230V and frequency to 50Hz.

**Note:** The voltage setting of the AC power supply in this step should be in accordance with the value selected by the voltage selector at the rear panel of DP800.

3. Turn on DP800 and press the channel selecting key at the front panel to select CH1 as the channel to be tested. Set the voltage and current of the channel under test according to Table 3-11. Then, press the **On/Off** key corresponding to the channel under test to enable the output of the channel.
4. Turn on the RMS voltmeter and select the AC voltage random measurement mode (SETACV RNDM). Make sure that the power supply is in CC mode. Read

and record the RMS value ( $V_{rms}$ ) measured by the RMS voltmeter.

**Note:** The measurement wires of the RMS voltmeter should be twisted together to minimize the effect of the space radiation noise on the test as much as possible.

5. Calculate the CC ripple and noise ( $V_{rms}/R_L$ ) and compare it with the specified specification in Table 3-11.
6. Press the **On/Off** key corresponding to the channel under test at the front channel to disable the output of the channel under test.
7. Repeat steps 1 to 6 to test the CC ripple and noise (normal mode) of CH2 and CH3 until finishing the CC ripple and noise tests of all channels.

**Notes:**

- During the CC ripple and noise test, please pay attention to shield the effect of the environmental space radiation noise on the test effectively.
- For the single channel model with multiple ranges of DP800 series (DP811A), please first select a range and set the corresponding parameters of this range in step 3 and then perform step 4 to step 6 to test the CC ripple and noise of this range. Then, repeat step 3 to step 6 to test the CC ripple and noise of the other range.
- For the channels that support the Sense function of DP800 series, please connect DP800, AC power supply, resistive load and RMS voltmeter according to Figure 2-2 and turn on the Sense function of the channel after selecting the current channel in step 3.

**Test Record Forms:**

Table 3-11 DP831A CC Ripple and Noise Test Record Form

| Channel              |                         | CH1 (8V/5A) | CH2 (30V/2A) | CH3 (-30V/2A) |
|----------------------|-------------------------|-------------|--------------|---------------|
| Specification        |                         | <2mArms     |              |               |
| Resistive Load $R_L$ |                         | 1.6Ω        | 15Ω          | 15Ω           |
| DP831A Setting       | Voltage                 | 8.4V        | 32V          | -32V          |
|                      | Current                 | 5A          | 2A           | 2A            |
| Measurement Result   | RMS value ( $V_{rms}$ ) |             |              |               |
|                      | $V_{rms}/R_L$           |             |              |               |

Table 3-12 DP832A CC Ripple and Noise Test Record Form

| Channel              |                  | CH1 (30V/3A) | CH2 (30V/3A) | CH3 (5V/3A)  |
|----------------------|------------------|--------------|--------------|--------------|
| Specification        |                  | <2mArms      |              |              |
| Resistive Load $R_L$ |                  | 10 $\Omega$  | 10 $\Omega$  | 1.6 $\Omega$ |
| DP832A Setting       | Voltage          | 32V          | 32V          | 5.3V         |
|                      | Current          | 3A           | 3A           | 3A           |
| Measurement Result   | RMS value (Vrms) |              |              |              |
|                      | Vrms/ $R_L$      |              |              |              |

Table 3-13 DP832 CC Ripple and Noise Test Record Form

| Channel              |                  | CH1 (30V/3A) | CH2 (30V/3A) | CH3 (5V/3A)  |
|----------------------|------------------|--------------|--------------|--------------|
| Specification        |                  | <2mArms      |              |              |
| Resistive Load $R_L$ |                  | 10 $\Omega$  | 10 $\Omega$  | 1.6 $\Omega$ |
| DP832 Setting        | Voltage          | 32V          | 32V          | 5.3V         |
|                      | Current          | 3A           | 3A           | 3A           |
| Measurement Result   | RMS value (Vrms) |              |              |              |
|                      | Vrms/ $R_L$      |              |              |              |

Table 3-14 DP821A CC Ripple and Noise Test Record Form

| Channel              |                  | CH1 (60V/1A) | CH2 (8V/10A) |
|----------------------|------------------|--------------|--------------|
| Specification        |                  | <2mArms      |              |
| Resistive Load $R_L$ |                  | 60 $\Omega$  | 0.8 $\Omega$ |
| DP821A Setting       | Voltage          | 63V          | 8.4V         |
|                      | Current          | 1A           | 10A          |
| Measurement Result   | RMS value (Vrms) |              |              |
|                      | Vrms/ $R_L$      |              |              |

Table 3-15 DP811A CC Ripple and Noise Test Record Form

| Range                |                  | Range1 (20V/10A) | Range2 (40V/5A) |
|----------------------|------------------|------------------|-----------------|
| Specification        |                  | <2mArms          |                 |
| Resistive Load $R_L$ |                  | 2 $\Omega$       | 8 $\Omega$      |
| DP811A Setting       | Voltage          | 21V              | 42V             |
|                      | Current          | 10A              | 5A              |
| Measurement Result   | RMS value (Vrms) |                  |                 |
|                      | Vrms/ $R_L$      |                  |                 |

## CC Programming and Readback Accuracy

CC programming accuracy refers to the error between the current setting value of the channel and the actual output current value when the power supply is in CC mode; CC readback accuracy refers to the error between the actual output current value and the readback current value when the power supply is in CC mode.

DP831A is taken as an example to test the CC programming and readback accuracy of DP800 series in the following section.

**Note:** During the actual test, please select the corresponding test record form according to the model of the DP800 power supply under test to set the corresponding parameters, record and calculate the corresponding specifications.

### Specification:

| Annual Accuracy <sup>[1]</sup> (25°C ± 5°C) ± (Output Percentage + Offset) |     |             |              |
|--|-----|-------------|--------------|
| Channel  |     | Programming | Readback     |
| DP831A   | CH1 | 0.2% + 10mA | 0.2% + 10mA  |
|  | CH2 | 0.2% + 5mA  | 0.1% + 5mA   |
|  | CH3 | 0.2% + 5mA  | 0.1% + 5mA   |
| DP832A   | CH1 | 0.2% + 5mA  | 0.15% + 5mA  |
|  | CH2 | 0.2% + 5mA  | 0.15% + 5mA  |
|  | CH3 | 0.2% + 5mA  | 0.15% + 5mA  |
| DP832  | CH1 | 0.2% + 10mA | 0.15% + 5mA  |
|  | CH2 | 0.2% + 10mA | 0.15% + 5mA  |
|  | CH3 | 0.2% + 10mA | 0.15% + 5mA  |
| DP821A   | CH1 | 0.2% + 10mA | 0.15% + 10mA |
|  | CH2 | 0.2% + 10mA | 0.15% + 10mA |
| DP811A   | CH1 | 0.1% + 10mA | 0.1% + 10mA  |

**Note<sup>[1]</sup>:** The accuracy parameters are acquired via calibration under 25°C after 1-hour warm-up.

### Test Procedures:

1. Turn off DP800. Connect DP800, AC power supply, current sampling resistor (the resistance  $R_M$  is 0.022Ω) and multimeter according to Figure 3-1. Please pay attention to the connection method of the current sampling resistor and the channel output terminals of DP800 as well as the connection method of the current sampling resistor and multimeter. Here, CH1 is taken as an example and the connection method is also applicable to CH2 and CH3. Then, connect the power supply with PC (take the connection via USB cable as an example) via the remote interfaces (USB, GPIB, LAN).

2. Turn on the AC power supply; set its voltage to 230V and frequency to 50Hz.

**Note:** The voltage setting of the AC power supply in this step should be in accordance with the value selected by the voltage selector at the rear panel of DP800.

3. Measure the CC programming and readback accuracy (take CH1 as an example in this place) when the output current is 0A.

- 1) Turn on DP800. Send the following commands via the remote interface to select the channel to be tested (namely the current channel), set the voltage and current of this channel (please refer to Table 3-16) as well as enable the output of this channel.

```
:APPL CH1,8.4,0      /*Select CH1 as the current channel and set the
                       voltage and current of this channel to 8.4V and
                       0A respectively*/
:OUTP CH1,ON        /*Enable the output of CH1*/
```

**Notes:**

- The above commands are only applicable to the multi-channel models of DP800. You can also send the `:INST:NSEL 1` (or `:INST CH1`) command to select CH1 as the current channel, the `:SOUR1:VOLT 8.4` command to set the voltage of CH1 to 8.4V and the `:SOUR1:CURRE 0` command to set the current of CH1 to 0A.
  - For the single channel model with multiple ranges of DP800 series (DP811A), you can send the `:OUTP:RANG P20V` (or `:OUTP:RANG LOW`, or `:VOLT:RANG P20V`, or `:VOLT:RANG LOW`) command to select Range1 as the current range and then send the `:VOLT 21` command to set the voltage of the channel to 21V and the `:CURRE 0` command to set the current of the channel to 0A.
- 2) Turn on the digital multimeter; select DC voltage measurement function and set the range to "Auto". Make sure that the power supply is in CC mode. Read and record the reading ( $U_1$ ) of the multimeter. Calculate the current value  $I_1=U_1/R_M$ .
  - 3) Send the `:MEAS:CURRE? CH1` command via the remote interface; read and record the returned current value  $I_2$  of the query command.
  - 4) Calculate the CC programming accuracy ( $|I_1-0|$ ) and the CC readback accuracy ( $|I_2-I_1|$ ). Compare them with the specified specifications in Table 3-16.

4. Measure the CC programming and readback accuracy (take CH1 as an example in this place) when the output current is the rated output value.

- 1) Send the following command via the remote interface to select the channel to be tested (namely the current channel) and set the voltage and current of this channel (please refer to Table 3-16).

```
:APPL CH1,8.4,5      /* Select CH1 as the current channel and set the
                        voltage and current of this channel to 8.4V and
                        5A respectively*/
```

**Notes:**

- The above command is only applicable to the multi-channel models of DP800. You can also send the `:INST:NSEL 1` (or `:INST CH1`) command to select CH1 as the current channel, the `:SOUR1:VOLT 8.4` command to set the voltage of CH1 to 8.4V and the `:SOUR1:CURREN 5` command to set the current of CH1 to 5A.
  - For the single channel model with multiple ranges of DP800 series (DP811A), you can send the `:OUTP:RANG P20V` (or `:OUTP:RANG LOW`, or `:VOLT:RANG P20V`, or `:VOLT:RANG LOW`) command to select Range1 as the current range and then send the `:VOLT 21` command to set the voltage of the channel to 21V and the `:CURR 10` command to set the current of the channel to 10A.
- 2) Make sure that the power supply is in CC mode. Read and record the reading ( $U_3$ ) of the multimeter. Calculate the current value  $I_3=U_3/R_M$ .
  - 3) Send the `:MEAS:CURREN? CH1` command via the remote interface; read and record the returned current value  $I_4$  of the query command.
  - 4) Calculate the CC programming accuracy ( $|I_3-I_R|$ ) and the CC readback accuracy ( $|I_4-I_3|$ ). Compare them with the specified specifications in Table 3-16. Wherein,  $I_R$  is the rated output current of the channel under test.
  - 5) Send the following command via the remote interface to disable the output of the channel under test.

```
:OUTP CH1,OFF      /*Disable the output of CH1*/
```

5. Repeat steps 1 to 4 to test the CC programming and readback accuracy of CH2 and CH3 until finishing the CC programming and readback accuracy tests of all channels.

**Note:** For the multi-channel models of DP800 series, please replace the "CH1" in the remote commands in steps 3 and 4 with "CH2" or "CH3" to select and set the corresponding channel.

**Notes:**

- For the single channel model with multiple ranges of DP800 series (DP811A), please first select Range1, set the parameters of Range1 and measure the CC programming and readback accuracy of this range in steps 3 and 4. Then, repeat steps 3 and 4 to test the CC programming and readback accuracy of Range2 (please replace the "P20V" or "LOW" in the remote commands in steps 3 and 4 with "P40V" or "HIGH").
- For the channels that support the Sense function of DP800 series, please connect DP800, AC power supply, current sampling resistor and multimeter according to Figure 3-2 and send the remote command (DP821A: :OUTP:SENS CH2,ON; DP811A: :OUTP:SENS CH1,ON) to turn on the Sense function of the channel under test before turning on the output of the channel under test in step 3.

**Test Record Forms:**

Table 3-16 DP831A CC Programming and Readback Accuracy Test Record Form

| Channel   |                                   | CH1 (8V/5A) | CH2 (30V/2A) | CH3 (-30V/2A) |
|---|-----------------------------------|-------------|--------------|---------------|
| Specification                                       | Programming                       | <20mA       | <9mA         | <9mA          |
|   | Readback                          | <20mA       | <7mA         | <7mA          |
| <b>The output current is 0</b>                      |                                   |             |              |               |
| DP831A Setting                                      | Voltage                           | 8.4V        | 32V          | -32V          |
|   | Current                           | 0A          | 0A           | 0A            |
| Measurement Result                                  | $U_1$                             |             |              |               |
|   | $I_1=U_1/R_M^{[1]}$               |             |              |               |
|   | $I_2$                             |             |              |               |
|   | Programming:<br>$ I_1-0 $         |             |              |               |
|   | Readback:<br>$ I_2-I_1 $          |             |              |               |
| <b>The output current is <math>I_R^{[2]}</math></b> |                                   |             |              |               |
| DP831A Setting                                      | Voltage                           | 8.4V        | 32V          | -32V          |
|   | Current                           | 5A          | 2A           | 2A            |
| Measurement Result                                  | $U_3$                             |             |              |               |
|   | $I_3=U_3/R_M^{[1]}$               |             |              |               |
|   | $I_4$                             |             |              |               |
|   | Programming:<br>$ I_3-I_R^{[2]} $ |             |              |               |
|   | Readback:<br>$ I_4-I_3 $          |             |              |               |

Note<sup>[1]</sup>:  $R_M=0.022\Omega$ .

Note<sup>[2]</sup>: The rated current of the specified channel.

Table 3-17 DP832A CC Programming and Readback Accuracy Test Record Form

| Channel   |                                   | CH1 (30V/3A) | CH2 (30V/3A) | CH3 (5V/3A) |
|---|-----------------------------------|--------------|--------------|-------------|
| Specification                                       | Programming                       | <11mA        |              |             |
|   | Readback                          | <9.5mA       |              |             |
| <b>The output current is 0</b>                      |                                   |              |              |             |
| DP832A Setting                                      | Voltage                           | 32V          | 32V          | 5.3V        |
|   | Current                           | 0A           | 0A           | 0A          |
| Measurement Result                                  | $U_1$                             |              |              |             |
|   | $I_1=U_1/R_M^{[1]}$               |              |              |             |
|   | $I_2$                             |              |              |             |
|   | Programming:<br>$ I_1-0 $         |              |              |             |
|   | Readback:<br>$ I_2-I_1 $          |              |              |             |
| <b>The output current is <math>I_R^{[2]}</math></b> |                                   |              |              |             |
| DP832A Setting                                      | Voltage                           | 32V          | 32V          | 5.3V        |
|   | Current                           | 3A           | 3A           | 3A          |
| Measurement Result                                  | $U_3$                             |              |              |             |
|   | $I_3=U_3/R_M^{[1]}$               |              |              |             |
|   | $I_4$                             |              |              |             |
|   | Programming:<br>$ I_3-I_R^{[2]} $ |              |              |             |
|   | Readback:<br>$ I_4-I_3 $          |              |              |             |

Note<sup>[1]</sup>:  $R_M=0.022\Omega$ .

Note<sup>[2]</sup>: The rated current of the specified channel.



Table 3-18 DP832 CC Programming and Readback Accuracy Test Record Form

| Channel   |                                   | CH1 (30V/3A) | CH2 (30V/3A) | CH3 (5V/3A) |
|---|-----------------------------------|--------------|--------------|-------------|
| Specification                                       | Programming                       | <16mA        |              |             |
|   | Readback                          | <9.5mA       |              |             |
| <b>The output current is 0</b>                      |                                   |              |              |             |
| DP832 Setting                                       | Voltage                           | 32V          | 32V          | 5.3V        |
|   | Current                           | 0A           | 0A           | 0A          |
| Measurement Result                                  | $U_1$                             |              |              |             |
|   | $I_1=U_1/R_M^{[1]}$               |              |              |             |
|   | $I_2$                             |              |              |             |
|   | Programming:<br>$ I_1-0 $         |              |              |             |
|   | Readback:<br>$ I_2-I_1 $          |              |              |             |
| <b>The output current is <math>I_R^{[2]}</math></b> |                                   |              |              |             |
| DP832 Setting                                       | Voltage                           | 32V          | 32V          | 5.3V        |
|   | Current                           | 3A           | 3A           | 3A          |
| Measurement Result                                  | $U_3$                             |              |              |             |
|   | $I_3=U_3/R_M^{[1]}$               |              |              |             |
|   | $I_4$                             |              |              |             |
|   | Programming:<br>$ I_3-I_R^{[2]} $ |              |              |             |
|   | Readback:<br>$ I_4-I_3 $          |              |              |             |

Note<sup>[1]</sup>:  $R_M=0.022\Omega$ .

Note<sup>[2]</sup>: The rated current of the specified channel.

Table 3-19 DP821A CC Programming and Readback Accuracy Test Record Form

| Channel   |                                   | CH1 (60V/1A) | CH2 (8V/10A) |
|---|-----------------------------------|--------------|--------------|
| Specification                                       | Programming                       | <12mA        | <30mA        |
|   | Readback                          | <11.5mA      | <25mA        |
| <b>The output current is 0</b>                      |                                   |              |              |
| DP821A Setting                                      | Voltage                           | 63V          | 8.4V         |
|   | Current                           | 0A           | 0A           |
| Measurement Result                                  | $U_1$                             |              |              |
|   | $I_1=U_1/R_M^{[1]}$               |              |              |
|   | $I_2$                             |              |              |
|   | Programming:<br>$ I_1-0 $         |              |              |
|   | Readback:<br>$ I_2-I_1 $          |              |              |
| <b>The output current is <math>I_R^{[2]}</math></b> |                                   |              |              |
| DP821A Setting                                      | Voltage                           | 63V          | 8.4V         |
|   | Current                           | 1A           | 10A          |
| Measurement Result                                  | $U_3$                             |              |              |
|   | $I_3=U_3/R_M^{[1]}$               |              |              |
|   | $I_4$                             |              |              |
|   | Programming:<br>$ I_3-I_R^{[2]} $ |              |              |
|   | Readback:<br>$ I_4-I_3 $          |              |              |

Note<sup>[1]</sup>:  $R_M=0.022\Omega$ .

Note<sup>[2]</sup>: The rated current of the specified channel.

Table 3-20 DP811A CC Programming and Readback Accuracy Test Record Form

| Range   |                                   | Range1 (20V/10A) | Range2 (40V/5A) |
|---|-----------------------------------|------------------|-----------------|
| Specification                                       | Programming                       | <20mA            | <15mA           |
|   | Readback                          | <20mA            | <15mA           |
| <b>The output current is 0</b>                      |                                   |                  |                 |
| DP811A Setting                                      | Voltage                           | 21V              | 42V             |
|   | Current                           | 0A               | 0A              |
| Measurement Result                                  | $U_1$                             |                  |                 |
|   | $I_1=U_1/R_M^{[1]}$               |                  |                 |
|   | $I_2$                             |                  |                 |
|   | Programming:<br>$ I_1-0 $         |                  |                 |
|   | Readback:<br>$ I_2-I_1 $          |                  |                 |
| <b>The output current is <math>I_R^{[2]}</math></b> |                                   |                  |                 |
| DP811A Setting                                      | Voltage                           | 21V              | 42V             |
|   | Current                           | 10A              | 5A              |
| Measurement Result                                  | $U_3$                             |                  |                 |
|   | $I_3=U_3/R_M^{[1]}$               |                  |                 |
|   | $I_4$                             |                  |                 |
|   | Programming:<br>$ I_3-I_R^{[2]} $ |                  |                 |
|   | Readback:<br>$ I_4-I_3 $          |                  |                 |

Note<sup>[1]</sup>:  $R_M=0.022\Omega$ .

Note<sup>[2]</sup>: The rated current of the specified range.



# Appendix

## Appendix A: Test Result Record Forms

### DP831A Performance Verification Test Record Form

**RIGOL DP831A Programmable Linear DC Power Supply  
Performance Verification Test Record Form**

#### CV Load Regulation Rate

| Channel            |             | CH1 (8V/5A) | CH2 (30V/2A) | CH3 (-30V/2A) |
|--------------------|-------------|-------------|--------------|---------------|
| Specification      |             | <2.8mV      | <5mV         | <5mV          |
| DP831A Setting     | Voltage     | 8V          | 30V          | -30V          |
|                    | Current     | 5.3A        | 2.1A         | 2.1A          |
| Measurement Result | $U_0$       |             |              |               |
|                    | $U_1$       |             |              |               |
|                    | $ U_1-U_0 $ |             |              |               |

#### CV Linear Regulation Rate

| Channel            |             | CH1 (8V/5A) | CH2 (30V/2A) | CH3 (-30V/2A) |
|--------------------|-------------|-------------|--------------|---------------|
| Specification      |             | <2.8mV      | <5mV         | <5mV          |
| DP831A Setting     | Voltage     | 8V          | 30V          | -30V          |
|                    | Current     | 5.3A        | 2.1A         | 2.1A          |
| Measurement Result | $U_0$       |             |              |               |
|                    | $U_1$       |             |              |               |
|                    | $U_2$       |             |              |               |
|                    | $ U_1-U_0 $ |             |              |               |
|                    | $ U_2-U_0 $ |             |              |               |

#### CV Ripple and Noise

| Channel              |                       | CH1 (8V/5A)           | CH2 (30V/2A) | CH3 (-30V/2A) |
|----------------------|-----------------------|-----------------------|--------------|---------------|
| Specification        |                       | <350 $\mu$ Vrms/3mVpp |              |               |
| Resistive Load $R_L$ |                       | 1.6 $\Omega$          | 15 $\Omega$  | 15 $\Omega$   |
| DP831A Setting       | Voltage               | 8V                    | 30V          | -30V          |
|                      | Current               | 5.3A                  | 2.1A         | 2.1A          |
| Measurement Result   | Peak-peak value (Vpp) |                       |              |               |
|                      | RMS value (Vrms)      |                       |              |               |

**Transient Response Time**

| Channel                         |         | CH1 (8V/5A) | CH2 (30V/2A) | CH3 (-30V/2A) |
|---------------------------------|---------|-------------|--------------|---------------|
| Specification                   |         | <50 $\mu$ s |              |               |
| DP831A Setting                  | Voltage | 8V          | 30V          | -30V          |
|                                 | Current | 5.3A        | 2.1A         | 2.1A          |
| Electronic Load Current Setting | CCDH1   | 5A          | 2A           | 2A            |
|                                 | CCDH2   | 2.5A        | 1A           | 1A            |
| Measurement Result              | t       |             |              |               |

**CV Programming and Readback Accuracy**

| Channel   |   | CH1 (8V/5A) | CH2 (30V/2A) | CH3 (-30V/2A) |
|---|---|-------------|--------------|---------------|
| Specification                                       | Programming   | <13mV       | <35mV        | <35mV         |
|   | Readback  | <13mV       | <25mV        | <25mV         |
| The output voltage is 0                             |   |             |              |               |
| DP831A Setting                                      | Voltage   | 0V          | 0V           | 0V            |
|   | Current   | 5.3A        | 2.1A         | 2.1A          |
| Measurement Result                                  | U <sub>1</sub>  |             |              |               |
|   | U <sub>2</sub>  |             |              |               |
|   | Programming:  U <sub>1</sub> -0                             |             |              |               |
|   | Readback:  U <sub>2</sub> -U <sub>1</sub>                   |             |              |               |
| The output voltage is U <sub>R</sub> <sup>[1]</sup> |   |             |              |               |
| DP831A Setting                                      | Voltage   | 8V          | 30V          | -30V          |
|   | Current   | 5.3A        | 2.1A         | 2.1A          |
| Measurement Result                                  | U <sub>3</sub>  |             |              |               |
|   | U <sub>4</sub>  |             |              |               |
|   | Programming:  U <sub>3</sub> -U <sub>R</sub> <sup>[1]</sup> |             |              |               |
|   | Readback:  U <sub>4</sub> -U <sub>3</sub>                   |             |              |               |

**CC Load Regulation Rate**

| Channel            |  | CH1 (8V/5A)  | CH2 (30V/2A) | CH3 (-30V/2A) |
|--------------------|--|--------------|--------------|---------------|
| Specification      |  | <750 $\mu$ A | <450 $\mu$ A | <450 $\mu$ A  |
| DP831A Setting     | Voltage  | 8.4V         | 32V          | -32V          |
|                    | Current  | 5A           | 2A           | 2A            |
| Measurement Result | U <sub>0</sub>   |              |              |               |
|                    | U <sub>1</sub>   |              |              |               |
|                    | U <sub>1</sub> /R <sub>M</sub> <sup>[2]</sup> -U <sub>0</sub> /R <sub>M</sub> <sup>[2]</sup> |              |              |               |

**CC Linear Regulation Rate**

| Channel               |                       | CH1 (8V/5A)  | CH2 (30V/2A) | CH3 (-30V/2A) |
|-----------------------|-----------------------|--------------|--------------|---------------|
| Specification         |                       | <750 $\mu$ A | <450 $\mu$ A | <450 $\mu$ A  |
| DP831A<br>Setting     | Voltage               | 8.4V         | 32V          | -32V          |
|                       | Current               | 5A           | 2A           | 2A            |
| Measurement<br>Result | $U_0$                 |              |              |               |
|                       | $U_1$                 |              |              |               |
|                       | $U_2$                 |              |              |               |
|                       | $ U_1-U_0 /R_M^{[2]}$ |              |              |               |
|                       | $ U_2-U_0 /R_M^{[2]}$ |              |              |               |

**CC Ripple and Noise**

| Channel               |                     | CH1 (8V/5A)  | CH2 (30V/2A) | CH3 (-30V/2A) |
|-----------------------|---------------------|--------------|--------------|---------------|
| Specification         |                     | <2mArms      |              |               |
| Resistive Load $R_L$  |                     | 1.6 $\Omega$ | 15 $\Omega$  | 15 $\Omega$   |
| DP831A<br>Setting     | Voltage             | 8.4V         | 32V          | -32V          |
|                       | Current             | 5A           | 2A           | 2A            |
| Measurement<br>Result | RMS value<br>(Vrms) |              |              |               |
|                       | Vrms/ $R_L$         |              |              |               |

## CC Programming and Readback Accuracy

| Channel   |                                   | CH1 (8V/5A) | CH2 (30V/2A) | CH3 (-30V/2A) |
|---|-----------------------------------|-------------|--------------|---------------|
| Specification                                       | Programming                       | <20mA       | <9mA         | <9mA          |
|   | Readback                          | <20mA       | <7mA         | <7mA          |
| <b>The output current is 0</b>                      |                                   |             |              |               |
| DP831A Setting                                      | Voltage                           | 8.4V        | 32V          | -32V          |
|   | Current                           | 0A          | 0A           | 0A            |
| Measurement Result                                  | $U_1$                             |             |              |               |
|   | $I_1=U_1/R_M^{[2]}$               |             |              |               |
|   | $I_2$                             |             |              |               |
|   | Programming:<br>$ I_1-0 $         |             |              |               |
|   | Readback:<br>$ I_2-I_1 $          |             |              |               |
| <b>The output current is <math>I_R^{[3]}</math></b> |                                   |             |              |               |
| DP831A Setting                                      | Voltage                           | 8.4V        | 32V          | -32V          |
|   | Current                           | 5A          | 2A           | 2A            |
| Measurement Result                                  | $U_3$                             |             |              |               |
|   | $I_3=U_3/R_M^{[2]}$               |             |              |               |
|   | $I_4$                             |             |              |               |
|   | Programming:<br>$ I_3-I_R^{[3]} $ |             |              |               |
|   | Readback:<br>$ I_4-I_3^1 $        |             |              |               |

Note<sup>[1]</sup>: The rated voltage of the specified channel.

Note<sup>[2]</sup>:  $R_M=0.022\Omega$ .

Note<sup>[3]</sup>: The rated current of the specified channel.



## DP832A Performance Verification Test Record Form

### RIGOL DP832A Programmable Linear DC Power Supply Performance Verification Test Record Form

#### CV Load Regulation Rate

| Channel            |             | CH1 (30V/3A) | CH2 (30V/3A) | CH3 (5V/3A) |
|--------------------|-------------|--------------|--------------|-------------|
| Specification      |             | <5mV         | <5mV         | <2.5mV      |
| DP832A Setting     | Voltage     | 30V          | 30V          | 5V          |
|                    | Current     | 3.2A         | 3.2A         | 3.2A        |
| Measurement Result | $U_0$       |              |              |             |
|                    | $U_1$       |              |              |             |
|                    | $ U_1-U_0 $ |              |              |             |

#### CV Linear Regulation Rate

| Channel            |             | CH1 (30V/3A) | CH2 (30V/3A) | CH3 (5V/3A) |
|--------------------|-------------|--------------|--------------|-------------|
| Specification      |             | <5mV         | <5mV         | <2.5mV      |
| DP832A Setting     | Voltage     | 30V          | 30V          | 5V          |
|                    | Current     | 3.2A         | 3.2A         | 3.2A        |
| Measurement Result | $U_0$       |              |              |             |
|                    | $U_1$       |              |              |             |
|                    | $U_2$       |              |              |             |
|                    | $ U_1-U_0 $ |              |              |             |
|                    | $ U_2-U_0 $ |              |              |             |

#### CV Ripple and Noise

| Channel              |                       | CH1 (30V/3A)          | CH2 (30V/3A) | CH3 (5V/3A)  |
|----------------------|-----------------------|-----------------------|--------------|--------------|
| Specification        |                       | <350 $\mu$ Vrms/3mVpp |              |              |
| Resistive Load $R_L$ |                       | 10 $\Omega$           | 10 $\Omega$  | 1.6 $\Omega$ |
| DP832A Setting       | Voltage               | 30V                   | 30V          | 5V           |
|                      | Current               | 3.2A                  | 3.2A         | 3.2A         |
| Measurement Result   | Peak-peak value (Vpp) |                       |              |              |
|                      | RMS value (Vrms)      |                       |              |              |

**Transient Response Time**

| Channel                         |         | CH1 (30V/3A) | CH2 (30V/3A) | CH3 (5V/3A) |
|---------------------------------|---------|--------------|--------------|-------------|
| Specification                   |         | <50 $\mu$ s  |              |             |
| DP832A Setting                  | Voltage | 30V          | 30V          | 5V          |
|                                 | Current | 3.2A         | 3.2A         | 3.2A        |
| Electronic Load Current Setting | CCDH1   | 3A           | 3A           | 3A          |
|                                 | CCDH2   | 1.5A         | 1.5A         | 1.5A        |
| Measurement Result              | t       |              |              |             |

**CV Programming and Readback Accuracy**

| Channel  |  | CH1 (30V/3A) | CH2 (30V/3A) | CH3 (5V/3A) |
|--|--|--------------|--------------|-------------|
| Specification  | Programming  | <35mV        | <35mV        | <10mV       |
|  | Readback   | <25mV        | <25mV        | <10mV       |
| <b>The output voltage is 0</b>                           |  |              |              |             |
| DP832A Setting   | Voltage  | 0V           | 0V           | 0V          |
|  | Current  | 3.2A         | 3.2A         | 3.2A        |
| Measurement Result                                       | U <sub>1</sub>   |              |              |             |
|  | U <sub>2</sub>   |              |              |             |
|  | Programming:<br> U <sub>1</sub> -0                             |              |              |             |
|  | Readback:<br> U <sub>2</sub> -U <sub>1</sub>                   |              |              |             |
| <b>The output voltage is U<sub>R</sub><sup>[1]</sup></b> |  |              |              |             |
| DP832A Setting   | Voltage  | 30V          | 30V          | 5V          |
|  | Current  | 3.2A         | 3.2A         | 3.2A        |
| Measurement Result                                       | U <sub>3</sub>   |              |              |             |
|  | U <sub>4</sub>   |              |              |             |
|  | Programming:<br> U <sub>3</sub> -U <sub>R</sub> <sup>[1]</sup> |              |              |             |
|  | Readback:<br> U <sub>4</sub> -U <sub>3</sub>                   |              |              |             |

**CC Load Regulation Rate**

| Channel            |                                   | CH1 (30V/3A) | CH2 (30V/3A) | CH3 (5V/3A) |
|--------------------|-----------------------------------|--------------|--------------|-------------|
| Specification      |                                   | <550 $\mu$ A |              |             |
| DP832A Setting     | Voltage                           | 32V          | 32V          | 5.3V        |
|                    | Current                           | 3A           | 3A           | 3A          |
| Measurement Result | $U_0$                             |              |              |             |
|                    | $U_1$                             |              |              |             |
|                    | $ U_1/R_M^{[2]} - U_0/R_M^{[2]} $ |              |              |             |

**CC Linear Regulation Rate**

| Channel            |                         | CH1 (30V/3A) | CH2 (30V/3A) | CH3 (5V/3A) |
|--------------------|-------------------------|--------------|--------------|-------------|
| Specification      |                         | <550 $\mu$ A |              |             |
| DP832A Setting     | Voltage                 | 32V          | 32V          | 5.3V        |
|                    | Current                 | 3A           | 3A           | 3A          |
| Measurement Result | $U_0$                   |              |              |             |
|                    | $U_1$                   |              |              |             |
|                    | $U_2$                   |              |              |             |
|                    | $ U_1 - U_0 /R_M^{[2]}$ |              |              |             |
|                    | $ U_2 - U_0 /R_M^{[2]}$ |              |              |             |

**CC Ripple and Noise**

| Channel              |                  | CH1 (30V/3A) | CH2 (30V/3A) | CH3 (5V/3A)  |
|----------------------|------------------|--------------|--------------|--------------|
| Specification        |                  | <2mArms      |              |              |
| Resistive Load $R_L$ |                  | 10 $\Omega$  | 10 $\Omega$  | 1.6 $\Omega$ |
| DP832A Setting       | Voltage          | 32V          | 32V          | 5.3V         |
|                      | Current          | 3A           | 3A           | 3A           |
| Measurement Result   | RMS value (Vrms) |              |              |              |
|                      | Vrms/ $R_L$      |              |              |              |

**CC Programming and Readback Accuracy**

| Channel   |                                   | CH1 (30V/3A) | CH2 (30V/3A) | CH3 (5V/3A) |
|---|-----------------------------------|--------------|--------------|-------------|
| Specification                                       | Programming                       | <11mA        |              |             |
|   | Readback                          | <9.5mA       |              |             |
| <b>The output current is 0</b>                      |                                   |              |              |             |
| DP832A Setting                                      | Voltage                           | 32V          | 32V          | 5.3V        |
|   | Current                           | 0A           | 0A           | 0A          |
| Measurement Result                                  | $U_1$                             |              |              |             |
|   | $I_1=U_1/R_M^{[2]}$               |              |              |             |
|   | $I_2$                             |              |              |             |
|   | Programming:<br>$ I_1-0 $         |              |              |             |
|   | Readback:<br>$ I_2-I_1 $          |              |              |             |
| <b>The output current is <math>I_R^{[3]}</math></b> |                                   |              |              |             |
| DP832A Setting                                      | Voltage                           | 32V          | 32V          | 5.3V        |
|   | Current                           | 3A           | 3A           | 3A          |
| Measurement Result                                  | $U_3$                             |              |              |             |
|   | $I_3=U_3/R_M^{[2]}$               |              |              |             |
|   | $I_4$                             |              |              |             |
|   | Programming:<br>$ I_3-I_R^{[3]} $ |              |              |             |
|   | Readback:<br>$ I_4-I_3 $          |              |              |             |

**Note<sup>[1]</sup>**: The rated voltage of the specified channel.

**Note<sup>[2]</sup>**:  $R_M=0.022\Omega$ .

**Note<sup>[3]</sup>**: The rated current of the specified channel.

## DP832 Performance Verification Test Record Form

### RIGOL DP832 Programmable Linear DC Power Supply Performance Verification Test Record Form

#### CV Load Regulation Rate

| Channel            |             | CH1 (30V/3A) | CH2 (30V/3A) | CH3 (5V/3A) |
|--------------------|-------------|--------------|--------------|-------------|
| Specification      |             | <5mV         | <5mV         | <2.5mV      |
| DP832 Setting      | Voltage     | 30V          | 30V          | 5V          |
|                    | Current     | 3.2A         | 3.2A         | 3.2A        |
| Measurement Result | $U_0$       |              |              |             |
|                    | $U_1$       |              |              |             |
|                    | $ U_1-U_0 $ |              |              |             |

#### CV Linear Regulation Rate

| Channel            |             | CH1 (30V/3A) | CH2 (30V/3A) | CH3 (5V/3A) |
|--------------------|-------------|--------------|--------------|-------------|
| Specification      |             | <5mV         | <5mV         | <2.5mV      |
| DP832 Setting      | Voltage     | 30V          | 30V          | 5V          |
|                    | Current     | 3.2A         | 3.2A         | 3.2A        |
| Measurement Result | $U_0$       |              |              |             |
|                    | $U_1$       |              |              |             |
|                    | $U_2$       |              |              |             |
|                    | $ U_1-U_0 $ |              |              |             |
|                    | $ U_2-U_0 $ |              |              |             |

#### CV Ripple and Noise

| Channel              |                       | CH1 (30V/3A)          | CH2 (30V/3A) | CH3 (5V/3A)  |
|----------------------|-----------------------|-----------------------|--------------|--------------|
| Specification        |                       | <350 $\mu$ Vrms/3mVpp |              |              |
| Resistive Load $R_L$ |                       | 10 $\Omega$           | 10 $\Omega$  | 1.6 $\Omega$ |
| DP832 Setting        | Voltage               | 30V                   | 30V          | 5V           |
|                      | Current               | 3.2A                  | 3.2A         | 3.2A         |
| Measurement Result   | Peak-peak value (Vpp) |                       |              |              |
|                      | RMS value (Vrms)      |                       |              |              |

**Transient Response Time**

| Channel                         |         | CH1 (30V/3A) | CH2 (30V/3A) | CH3 (5V/3A) |
|---------------------------------|---------|--------------|--------------|-------------|
| Specification                   |         | <50 $\mu$ s  |              |             |
| DP832 Setting                   | Voltage | 30V          | 30V          | 5V          |
|                                 | Current | 3.2A         | 3.2A         | 3.2A        |
| Electronic Load Current Setting | CCDH1   | 3A           | 3A           | 3A          |
|                                 | CCDH2   | 1.5A         | 1.5A         | 1.5A        |
| Measurement Result              | t       |              |              |             |

**CV Programming and Readback Accuracy**

| Channel  |  | CH1 (30V/3A) | CH2 (30V/3A) | CH3 (5V/3A) |
|--|--|--------------|--------------|-------------|
| Specification  | Programming  | <25mV        | <25mV        | <12.5mV     |
|  | Readback   | <20mV        | <20mV        | <7.5mV      |
| <b>The output voltage is 0</b>                           |  |              |              |             |
| DP832 Setting  | Voltage  | 0V           | 0V           | 0V          |
|  | Current  | 3.2A         | 3.2A         | 3.2A        |
| Measurement Result                                       | U <sub>1</sub>   |              |              |             |
|  | U <sub>2</sub>   |              |              |             |
|  | Programming:<br> U <sub>1</sub> -0                             |              |              |             |
|  | Readback:<br> U <sub>2</sub> -U <sub>1</sub>                   |              |              |             |
| <b>The output voltage is U<sub>R</sub><sup>[1]</sup></b> |  |              |              |             |
| DP832 Setting  | Voltage  | 30V          | 30V          | 5V          |
|  | Current  | 3.2A         | 3.2A         | 3.2A        |
| Measurement Result                                       | U <sub>3</sub>   |              |              |             |
|  | U <sub>4</sub>   |              |              |             |
|  | Programming:<br> U <sub>3</sub> -U <sub>R</sub> <sup>[1]</sup> |              |              |             |
|  | Readback:<br> U <sub>4</sub> -U <sub>3</sub>                   |              |              |             |

**CC Load Regulation Rate**

| Channel            |                                   | CH1 (30V/3A) | CH2 (30V/3A) | CH3 (5V/3A) |
|--------------------|-----------------------------------|--------------|--------------|-------------|
| Specification      |                                   | <550 $\mu$ A |              |             |
| DP832 Setting      | Voltage                           | 32V          | 32V          | 5.3V        |
|                    | Current                           | 3A           | 3A           | 3A          |
| Measurement Result | $U_0$                             |              |              |             |
|                    | $U_1$                             |              |              |             |
|                    | $ U_1/R_M^{[2]} - U_0/R_M^{[2]} $ |              |              |             |

**CC Linear Regulation Rate**

| Channel            |                         | CH1 (30V/3A) | CH2 (30V/3A) | CH3 (5V/3A) |
|--------------------|-------------------------|--------------|--------------|-------------|
| Specification      |                         | <550 $\mu$ A |              |             |
| DP832 Setting      | Voltage                 | 32V          | 32V          | 5.3V        |
|                    | Current                 | 3A           | 3A           | 3A          |
| Measurement Result | $U_0$                   |              |              |             |
|                    | $U_1$                   |              |              |             |
|                    | $U_2$                   |              |              |             |
|                    | $ U_1 - U_0 /R_M^{[2]}$ |              |              |             |
|                    | $ U_2 - U_0 /R_M^{[2]}$ |              |              |             |

**CC Ripple and Noise**

| Channel              |                  | CH1 (30V/3A) | CH2 (30V/3A) | CH3 (5V/3A)  |
|----------------------|------------------|--------------|--------------|--------------|
| Specification        |                  | <2mArms      |              |              |
| Resistive Load $R_L$ |                  | 10 $\Omega$  | 10 $\Omega$  | 1.6 $\Omega$ |
| DP832 Setting        | Voltage          | 32V          | 32V          | 5.3V         |
|                      | Current          | 3A           | 3A           | 3A           |
| Measurement Result   | RMS value (Vrms) |              |              |              |
|                      | Vrms/ $R_L$      |              |              |              |

### CC Programming and Readback Accuracy

| Channel   |                                   | CH1 (30V/3A) | CH2 (30V/3A) | CH3 (5V/3A) |
|---|-----------------------------------|--------------|--------------|-------------|
| Specification                                       | Programming                       | <16mA        |              |             |
|   | Readback                          | <9.5mA       |              |             |
| <b>The output current is 0</b>                      |                                   |              |              |             |
| DP832 Setting                                       | Voltage                           | 32V          | 32V          | 5.3V        |
|   | Current                           | 0A           | 0A           | 0A          |
| Measurement Result                                  | $U_1$                             |              |              |             |
|   | $I_1=U_1/R_M^{[2]}$               |              |              |             |
|   | $I_2$                             |              |              |             |
|   | Programming:<br>$ I_1-0 $         |              |              |             |
|   | Readback:<br>$ I_2-I_1 $          |              |              |             |
| <b>The output current is <math>I_R^{[3]}</math></b> |                                   |              |              |             |
| DP832 Setting                                       | Voltage                           | 32V          | 32V          | 5.3V        |
|   | Current                           | 3A           | 3A           | 3A          |
| Measurement Result                                  | $U_3$                             |              |              |             |
|   | $I_3=U_3/R_M^{[2]}$               |              |              |             |
|   | $I_4$                             |              |              |             |
|   | Programming:<br>$ I_3-I_R^{[3]} $ |              |              |             |
|   | Readback:<br>$ I_4-I_3 $          |              |              |             |

**Note**<sup>[1]</sup>: The rated voltage of the specified channel.

**Note**<sup>[2]</sup>:  $R_M=0.022\Omega$ .

**Note**<sup>[3]</sup>: The rated current of the specified channel.



## DP821A Performance Verification Test Record Form

### RIGOL DP821A Programmable Linear DC Power Supply Performance Verification Test Record Form

#### CV Load Regulation Rate

| Channel            |             | CH1 (60V/1A) | CH2 (8V/10A) |
|--------------------|-------------|--------------|--------------|
| Specification      |             | <8mV         | <2.8mV       |
| DP821A Setting     | Voltage     | 60V          | 8V           |
|                    | Current     | 1.05A        | 10.5A        |
| Measurement Result | $U_0$       |              |              |
|                    | $U_1$       |              |              |
|                    | $ U_1-U_0 $ |              |              |

#### CV Linear Regulation Rate

| Channel            |             | CH1 (60V/1A) | CH2 (8V/10A) |
|--------------------|-------------|--------------|--------------|
| Specification      |             | <8mV         | <2.8mV       |
| DP821A Setting     | Voltage     | 60V          | 8V           |
|                    | Current     | 1.05A        | 10.5A        |
| Measurement Result | $U_0$       |              |              |
|                    | $U_1$       |              |              |
|                    | $U_2$       |              |              |
|                    | $ U_1-U_0 $ |              |              |
|                    | $ U_2-U_0 $ |              |              |

#### CV Ripple and Noise

| Channel              |                       | CH1 (60V/1A)          | CH2 (8V/10A) |
|----------------------|-----------------------|-----------------------|--------------|
| Specification        |                       | <350 $\mu$ Vrms/3mVpp |              |
| Resistive Load $R_L$ |                       | 60 $\Omega$           | 0.8 $\Omega$ |
| DP821A Setting       | Voltage               | 60V                   | 8V           |
|                      | Current               | 1.05A                 | 10.5A        |
| Measurement Result   | Peak-peak value (Vpp) |                       |              |
|                      | RMS value (Vrms)      |                       |              |

**Transient Response Time**

| Channel                         |         | CH1 (60V/1A) | CH2 (8V/10A) |
|---------------------------------|---------|--------------|--------------|
| Specification                   |         | <50 $\mu$ s  |              |
| DP821A Setting                  | Voltage | 60V          | 8V           |
|                                 | Current | 1.05A        | 10.5A        |
| Electronic Load Current Setting | CCDH1   | 1A           | 10A          |
|                                 | CCDH2   | 0.5A         | 5A           |
| Measurement Result              | t       |              |              |

**CV Programming and Readback Accuracy**

| Channel  |  | CH1 (60V/1A) | CH2 (8V/10A) |
|--|--|--------------|--------------|
| Specification  | Programming  | <85mV        | <14mV        |
|  | Readback   | <85mV        | <9mV         |
| <b>The output voltage is 0</b>                           |  |              |              |
| DP821A Setting   | Voltage  | 0V           | 0V           |
|  | Current  | 1.05A        | 10.5A        |
| Measurement Result                                       | U <sub>1</sub>   |              |              |
|  | U <sub>2</sub>   |              |              |
|  | Programming:<br> U <sub>1</sub> -0                             |              |              |
|  | Readback:<br> U <sub>2</sub> -U <sub>1</sub>                   |              |              |
| <b>The output voltage is U<sub>R</sub><sup>[1]</sup></b> |  |              |              |
| DP821A Setting   | Voltage  | 60V          | 8V           |
|  | Current  | 1.05A        | 10.5A        |
| Measurement Result                                       | U <sub>1</sub>   |              |              |
|  | U <sub>2</sub>   |              |              |
|  | Programming:<br> U <sub>3</sub> -U <sub>R</sub> <sup>[1]</sup> |              |              |
|  | Readback:<br> U <sub>4</sub> -U <sub>3</sub>                   |              |              |

**CC Load Regulation Rate**

| Channel            |                                   | CH1 (60V/1A) | CH2 (8V/10A) |
|--------------------|-----------------------------------|--------------|--------------|
| Specification      |                                   | <350μA       | <1.25mA      |
| DP821A Setting     | Voltage                           | 63V          | 8.4V         |
|                    | Current                           | 1A           | 10A          |
| Measurement Result | $U_0$                             |              |              |
|                    | $U_1$                             |              |              |
|                    | $ U_1/R_M^{[2]} - U_0/R_M^{[2]} $ |              |              |

**CC Linear Regulation Rate**

| Channel            |                         | CH1 (60V/1A) | CH2 (8V/10A) |
|--------------------|-------------------------|--------------|--------------|
| Specification      |                         | <350μA       | <1.25mA      |
| DP821A Setting     | Voltage                 | 63V          | 8.4V         |
|                    | Current                 | 1A           | 10A          |
| Measurement Result | $U_0$                   |              |              |
|                    | $U_1$                   |              |              |
|                    | $U_2$                   |              |              |
|                    | $ U_1 - U_0 /R_M^{[2]}$ |              |              |
|                    | $ U_2 - U_0 /R_M^{[2]}$ |              |              |

**CC Ripple and Noise**

| Channel              |                  | CH1 (60V/1A) | CH2 (8V/10A) |
|----------------------|------------------|--------------|--------------|
| Specification        |                  | <2mArms      |              |
| Resistive Load $R_L$ |                  | 60Ω          | 0.8Ω         |
| DP821A Setting       | Voltage          | 63V          | 8.4V         |
|                      | Current          | 1A           | 10A          |
| Measurement Result   | RMS value (Vrms) |              |              |
|                      | Vrms/ $R_L$      |              |              |

**CC Programming and Readback Accuracy**

| Channel   |                                   | CH1 (60V/1A) | CH2 (8V/10A) |
|---|-----------------------------------|--------------|--------------|
| Specification                                       | Programming                       | <12mA        | <30mA        |
|   | Readback                          | <11.5mA      | <25mA        |
| <b>The output current is 0</b>                      |                                   |              |              |
| DP821A Setting                                      | Voltage                           | 63V          | 8.4V         |
|   | Current                           | 0A           | 0A           |
| Measurement Result                                  | $U_1$                             |              |              |
|   | $I_1=U_1/R_M^{[2]}$               |              |              |
|   | $I_2$                             |              |              |
|   | Programming:<br>$ I_1-0 $         |              |              |
|   | Readback:<br>$ I_2-I_1 $          |              |              |
| <b>The output current is <math>I_R^{[3]}</math></b> |                                   |              |              |
| DP821A Setting                                      | Voltage                           | 63V          | 8.4V         |
|   | Current                           | 1A           | 10A          |
| Measurement Result                                  | $U_3$                             |              |              |
|   | $I_3=U_3/R_M^{[2]}$               |              |              |
|   | $I_4$                             |              |              |
|   | Programming:<br>$ I_3-I_R^{[3]} $ |              |              |
|   | Readback:<br>$ I_4-I_3 $          |              |              |

**Note<sup>[1]</sup>**: The rated voltage of the specified channel.

**Note<sup>[2]</sup>**:  $R_M=0.022\Omega$ .

**Note<sup>[3]</sup>**: The rated current of the specified channel.

## DP811A Performance Verification Test Record Form

### RIGOL DP811A Programmable Linear DC Power Supply Performance Verification Test Record Form

#### CV Load Regulation Rate

| Range              |             | Range1 (20V/10A) | Range2 (40V/5A) |
|--------------------|-------------|------------------|-----------------|
| Specification      |             | <4mV             | <6mV            |
| DP811A Setting     | Voltage     | 20V              | 40V             |
|                    | Current     | 10.5A            | 5.3A            |
| Measurement Result | $U_0$       |                  |                 |
|                    | $U_1$       |                  |                 |
|                    | $ U_1-U_0 $ |                  |                 |

#### CV Linear Regulation Rate

| Range              |                       | Range1 (20V/10A) | Range2 (40V/5A) |
|--------------------|-----------------------|------------------|-----------------|
| Specification      |                       | <1.25mA          | <750 $\mu$ A    |
| DP811A Setting     | Voltage               | 21V              | 42V             |
|                    | Current               | 10A              | 5A              |
| Measurement Result | $U_0$                 |                  |                 |
|                    | $U_1$                 |                  |                 |
|                    | $U_2$                 |                  |                 |
|                    | $ U_1-U_0 /R_M^{[1]}$ |                  |                 |
|                    | $ U_2-U_0 /R_M^{[1]}$ |                  |                 |

#### CV Ripple and Noise

| Range                |                       | Range1 (20V/10A)      | Range2 (40V/5A) |
|----------------------|-----------------------|-----------------------|-----------------|
| Specification        |                       | <350 $\mu$ Vrms/3mVpp |                 |
| Resistive Load $R_L$ |                       | 2 $\Omega$            | 8 $\Omega$      |
| DP811A Setting       | Voltage               | 20V                   | 40V             |
|                      | Current               | 10.5A                 | 5.3A            |
| Measurement Result   | Peak-peak value (Vpp) |                       |                 |
|                      | RMS value (Vrms)      |                       |                 |

**Transient Response Time**

| Range                           |         | Range1 (20V/10A) | Range2 (40V/5A) |
|---------------------------------|---------|------------------|-----------------|
| Specification                   |         | $<50\mu\text{s}$ |                 |
| DP811A Setting                  | Voltage | 20V              | 40V             |
|                                 | Current | 10.5A            | 5.3A            |
| Electronic Load Current Setting | CCDH1   | 10A              | 5A              |
|                                 | CCDH2   | 5A               | 2.5A            |
| Measurement Result              | t       |                  |                 |

**CV Programming and Readback Accuracy**

| Range   |                                   | Range1 (20V/10A) | Range2 (40V/5A) |
|---|-----------------------------------|------------------|-----------------|
| Specification                                       | Programming                       | $<20\text{mV}$   | $<30\text{mV}$  |
|   | Readback                          | $<20\text{mV}$   | $<30\text{mV}$  |
| <b>The output voltage is 0</b>                      |                                   |                  |                 |
| DP811A Setting                                      | Voltage                           | 0V               | 0V              |
|   | Current                           | 10.5A            | 5.3A            |
| Measurement Result                                  | $U_1$                             |                  |                 |
|   | $U_2$                             |                  |                 |
|   | Programming:<br>$ U_1-0 $         |                  |                 |
|   | Readback:<br>$ U_2-U_1 $          |                  |                 |
| <b>The output voltage is <math>U_R^{[1]}</math></b> |                                   |                  |                 |
| DP811A Setting                                      | Voltage                           | 20V              | 40V             |
|   | Current                           | 10.5A            | 5.3A            |
| Measurement Result                                  | $U_1$                             |                  |                 |
|   | $U_2$                             |                  |                 |
|   | Programming:<br>$ U_3-U_R^{[1]} $ |                  |                 |
|   | Readback:<br>$ U_4-U_3 $          |                  |                 |

**CC Load Regulation Rate**

| Range              |                                   | Range1 (20V/10A) | Range2 (40V/5A) |
|--------------------|-----------------------------------|------------------|-----------------|
| Specification      |                                   | <1.25mA          | <750μA          |
| DP811A Setting     | Voltage                           | 21V              | 42V             |
|                    | Current                           | 10A              | 5A              |
| Measurement Result | $U_0$                             |                  |                 |
|                    | $U_1$                             |                  |                 |
|                    | $ U_1/R_M^{[2]} - U_0/R_M^{[2]} $ |                  |                 |

**CC Linear Regulation Rate**

| Range              |                         | Range1 (20V/10A) | Range2 (40V/5A) |
|--------------------|-------------------------|------------------|-----------------|
| Specification      |                         | <1.25mA          | <750μA          |
| DP811A Setting     | Voltage                 | 21V              | 42V             |
|                    | Current                 | 10A              | 5A              |
| Measurement Result | $U_0$                   |                  |                 |
|                    | $U_1$                   |                  |                 |
|                    | $U_2$                   |                  |                 |
|                    | $ U_1 - U_0 /R_M^{[2]}$ |                  |                 |
|                    | $ U_2 - U_0 /R_M^{[2]}$ |                  |                 |

**CC Ripple and Noise**

| Range                |                  | Range1 (20V/10A) | Range2 (40V/5A) |
|----------------------|------------------|------------------|-----------------|
| Specification        |                  | <2mArms          |                 |
| Resistive Load $R_L$ |                  | 2Ω               | 8Ω              |
| DP811A Setting       | Voltage          | 21V              | 42V             |
|                      | Current          | 10A              | 5A              |
| Measurement Result   | RMS value (Vrms) |                  |                 |
|                      | Vrms/ $R_L$      |                  |                 |

**CC Programming and Readback Accuracy**

| Range   |                                   | Range1 (20V/10A) | Range2 (40V/5A) |
|---|-----------------------------------|------------------|-----------------|
| Specification                                       | Programming                       | <20mA            | <15mA           |
|   | Readback                          | <20mA            | <15mA           |
| <b>The output current is 0</b>                      |                                   |                  |                 |
| DP811A Setting                                      | Voltage                           | 21V              | 42V             |
|   | Current                           | 0A               | 0A              |
| Measurement Result                                  | $U_1$                             |                  |                 |
|   | $I_1=U_1/R_M^{[2]}$               |                  |                 |
|   | $I_2$                             |                  |                 |
|   | Programming:<br>$ I_1-0 $         |                  |                 |
|   | Readback:<br>$ I_2-I_1 $          |                  |                 |
| <b>The output current is <math>I_R^{[3]}</math></b> |                                   |                  |                 |
| DP811A Setting                                      | Voltage                           | 21V              | 42V             |
|   | Current                           | 10A              | 5A              |
| Measurement Result                                  | $U_3$                             |                  |                 |
|   | $I_3=U_3/R_M^{[2]}$               |                  |                 |
|   | $I_4$                             |                  |                 |
|   | Programming:<br>$ I_3-I_R^{[3]} $ |                  |                 |
|   | Readback:<br>$ I_4-I_3 $          |                  |                 |

Note<sup>[1]</sup>: The rated voltage of the specified range.

Note<sup>[2]</sup>:  $R_M=0.022\Omega$ .

Note<sup>[3]</sup>: The rated current of the specified range.



## Appendix B: Specifications

The following parameters can only be guaranteed when the instrument has been operated continuously for more than 30 minutes under the specified operating temperature.

**Note:** Unless otherwise noted, the specifications below apply to all channels (ranges) of the specified model.

| DC Output (0°C-40°C) |        |             |         |                        |                        |
|----------------------|--------|-------------|---------|------------------------|------------------------|
| Channel              |        | Rated Value |         | Maximum Settable Range |                        |
|                      |        | Voltage     | Current | Overvoltage Protection | Overcurrent Protection |
| DP831A               | CH1    | 0V~8V       | 0A~5A   | 1mV~8.8V               | 0.1mA~5.5A             |
|                      | CH2    | 0V~30V      | 0A~2A   | 1mV~33V                | 0.1mA~2.2A             |
|                      | CH3    | -30V~0V     | 0A~2A   | -1mV~-33V              | 0.1mA~2.2A             |
| DP832A               | CH1    | 0V~30V      | 0A~3A   | 1mV~33V                | 1mA~3.3A               |
|                      | CH2    | 0V~30V      | 0A~3A   | 1mV~33V                | 1mA~3.3A               |
|                      | CH3    | 0V~5V       | 0A~3A   | 1mV~5.5V               | 1mA~3.3A               |
| DP832                | CH1    | 0V~30V      | 0A~3A   | 10mV~33V               | 1mA~3.3A               |
|                      | CH2    | 0V~30V      | 0A~3A   | 10mV~33V               | 1mA~3.3A               |
|                      | CH3    | 0V~5V       | 0A~3A   | 10mV~5.5V              | 1mA~3.3A               |
| DP821A               | CH1    | 0V~60V      | 0A~1A   | 1mV~66V                | 0.1mA~1.1A             |
|                      | CH2    | 0V~8V       | 0A~10A  | 1mV~8.8V               | 1mA~11A                |
| DP811A               | Range1 | 0V~20V      | 0A~10A  | 1mV~22V                | 0.1mA~11A              |
|                      | Range2 | 0V~40V      | 0A~5A   | 1mV~44V                | 0.1mA~5.5A             |

| Load Regulation rate, ±(Output Percentage+Offset) |              |
|---|--------------|
| Voltage   | <0.01%+2mV   |
| Current   | <0.01%+250μA |

| Linear Regulation Rate, ±(Output Percentage+Offset) |              |
|---|--------------|
| Voltage   | <0.01%+2mV   |
| Current   | <0.01%+250μA |

| Ripple and Noise (20 Hz to 20 MHz) |                 |
|------------------------------------|-----------------|
| Normal Mode Voltage                | <350μVrms/2mVpp |
| Normal Mode Current                | <2mArms         |

| Annual Accuracy <sup>[1]</sup> (25°C ±5°C) ±(Output Percentage+Offset) |     |             |           |            |            |
|--|-----|-------------|-----------|------------|------------|
| Channel  |     | Programming |           | Readback   |            |
|  |     | Voltage     | Current   | Voltage    | Current    |
| DP831A   | CH1 | 0.1%+5mV    | 0.2%+10mA | 0.1%+5mV   | 0.2%+10mA  |
|  | CH2 | 0.05%+20mV  | 0.2%+5mA  | 0.05%+10mV | 0.1%+5mA   |
|  | CH3 | 0.05%+20mV  | 0.2%+5mA  | 0.05%+10mV | 0.1%+5mA   |
| DP832A   | CH1 | 0.05%+20mV  | 0.2%+5mA  | 0.05%+10mV | 0.15%+5mA  |
|  | CH2 | 0.05%+20mV  | 0.2%+5mA  | 0.05%+10mV | 0.15%+5mA  |
|  | CH3 | 0.1%+5mV    | 0.2%+5mA  | 0.1%+5mV   | 0.15%+5mA  |
| DP832  | CH1 | 0.05%+10mV  | 0.2%+10mA | 0.05%+5mV  | 0.15%+5mA  |
|  | CH2 | 0.05%+10mV  | 0.2%+10mA | 0.05%+5mV  | 0.15%+5mA  |
|  | CH3 | 0.05%+10mV  | 0.2%+10mA | 0.05%+5mV  | 0.15%+5mA  |
| DP821A   | CH1 | 0.1%+25mV   | 0.2%+10mA | 0.1%+25mV  | 0.15%+10mA |
|  | CH2 | 0.05%+10mV  | 0.2%+10mA | 0.05%+5mV  | 0.15%+10mA |
| DP811A   | CH1 | 0.05%+10mV  | 0.1%+10mA | 0.05%+10mV | 0.1%+10mA  |

| Resolution           |     |             |         |          |         |         |         |
|----------------------|-----|-------------|---------|----------|---------|---------|---------|
| Channel              |     | Programming |         | Readback |         | Display |         |
|                      |     | Voltage     | Current | Voltage  | Current | Voltage | Current |
| DP831A               | CH1 | 1mV         | 0.3mA   | 0.1mV    | 0.1mA   | 1mV     | 1mA     |
|                      | CH2 | 1mV         | 0.1mA   | 0.1mV    | 0.1mA   | 1mV     | 1mA     |
|                      | CH3 | 1mV         | 0.1mA   | 0.1mV    | 0.1mA   | 1mV     | 1mA     |
| DP832A               | CH1 | 1mV         | 1mA     | 0.1mV    | 0.1mA   | 1mV     | 1mA     |
|                      | CH2 | 1mV         | 1mA     | 0.1mV    | 0.1mA   | 1mV     | 1mA     |
|                      | CH3 | 1mV         | 1mA     | 0.1mV    | 0.1mA   | 1mV     | 1mA     |
| DP832 <sup>[2]</sup> | CH1 | 10mV        | 1mA     | 10mV     | 1mA     | 10mV    | 10mA    |
|                      | CH2 | 10mV        | 1mA     | 10mV     | 1mA     | 10mV    | 10mA    |
|                      | CH3 | 10mV        | 1mA     | 10mV     | 1mA     | 10mV    | 10mA    |
| DP821A               | CH1 | 10mV        | 0.1mA   | 1mV      | 0.1mA   | 1mV     | 0.1mA   |
|                      | CH2 | 1mV         | 1mA     | 1mV      | 1mA     | 1mV     | 1mA     |
| DP811A               | CH1 | 1mV         | 0.5mA   | 0.1mV    | 0.1mA   | 1mV     | 1mA     |

#### Transient Response Time

Less than 50μs for output voltage to recover to within 15 mV following a change in output current from full load to half load or vice versa.

#### Command Processing Time<sup>[3]</sup>

<118ms

| Temperature Coefficient per°C (Output Percentage+Offset) |     |           |           |
|--|-----|-----------|-----------|
| Channel  |     | Voltage   | Current   |
| DP831A   | CH1 | 0.01%+2mV | 0.02%+3mA |
|  | CH2 | 0.01%+2mV | 0.02%+3mA |
|  | CH3 | 0.01%+2mV | 0.02%+3mA |
| DP832A   | CH1 | 0.01%+5mV | 0.01%+2mA |
|  | CH2 | 0.01%+5mV | 0.01%+2mA |
|  | CH3 | 0.01%+2mV | 0.01%+2mA |
| DP832  | CH1 | 0.01%+5mV | 0.01%+2mA |
|  | CH2 | 0.01%+5mV | 0.01%+2mA |
|  | CH3 | 0.01%+2mV | 0.01%+2mA |
| DP821A   | CH1 | 0.01%+3mV | 0.02%+3mA |
|  | CH2 | 0.01%+3mV | 0.02%+3mA |
| DP811A   | CH1 | 0.01%+3mV | 0.02%+3mA |

| Stability <sup>[4]</sup> , ± (Output Percentage+Offset) |     |           |           |
|---|-----|-----------|-----------|
| Channel   |     | Voltage   | Current   |
| DP831A  | CH1 | 0.03%+1mV | 0.1%+3mA  |
|   | CH2 | 0.02%+2mV | 0.05%+1mA |
|   | CH3 | 0.02%+2mV | 0.05%+1mA |
| DP832A  | CH1 | 0.02%+2mV | 0.05%+2mA |
|   | CH2 | 0.02%+2mV | 0.05%+2mA |
|   | CH3 | 0.01%+1mV | 0.05%+2mA |
| DP832   | CH1 | 0.02%+2mV | 0.05%+2mA |
|   | CH2 | 0.02%+2mV | 0.05%+2mA |
|   | CH3 | 0.01%+1mV | 0.05%+2mA |
| DP821A  | CH1 | 0.02%+1mV | 0.1%+1mA  |
|   | CH2 | 0.02%+1mV | 0.1%+1mA  |
| DP811A  | CH1 | 0.02%+1mV | 0.1%+1mA  |

| Voltage Programming Control Speed (1% within the total variation range) |     |           |         |           |         |
|---|-----|-----------|---------|-----------|---------|
| Channel   |     | Rise      |         | Fall      |         |
|   |     | Full Load | No Load | Full Load | No Load |
| DP831A  | CH1 | <18ms     | <17ms   | <20ms     | <200ms  |
|   | CH2 | <33ms     | <36ms   | <44ms     | <400ms  |
|   | CH3 | <35ms     | <42ms   | <45ms     | <400ms  |
| DP832A  | CH1 | <50ms     | <33ms   | <46ms     | <400ms  |
|   | CH2 | <50ms     | <38ms   | <46ms     | <400ms  |
|   | CH3 | <15ms     | <14ms   | <24ms     | <100ms  |
| DP832   | CH1 | <50ms     | <33ms   | <46ms     | <400ms  |
|   | CH2 | <50ms     | <38ms   | <46ms     | <400ms  |
|   | CH3 | <15ms     | <14ms   | <24ms     | <100ms  |
| DP821A  | CH1 | <92ms     | <30ms   | <90ms     | <486ms  |
|   | CH2 | <11ms     | <15ms   | <17ms     | <154ms  |
| DP811A  | CH1 | <45ms     | <42ms   | <51ms     | <1089ms |

| OVP/OCP                                   |  |
|---|--|
| Accuracy $\pm$ (Output Percentage+Offset) | 0.5%+0.5V/0.5%+0.5A                                    |
| Activation Time                           | 1.5ms (OVP $\geq$ 3V)<br><10ms (OVP<3V)<br><10ms (OCP) |

| Mechanical |  |
|------------|--|
| Dimensions | 239mm (W) x 157mm (H) x 418mm (D)  |
| Weight     | DP831A: 9.75kg<br>DP832A: 10.5kg<br>DP832: 9.0kg<br>DP821A: 10.0kg<br>DP811A: 10.3kg |

| Power                   |   |
|-------------------------|---|
| AC Input (50Hz to 60Hz) | 100Vac $\pm$ 10%, 115Vac $\pm$ 10%, 230Vac $\pm$ 10% (maximum 250Vac) |

| I/O                   |                     |
|-----------------------|---------------------|
| USB Device            | 1                   |
| USB Host              | 1                   |
| LAN                   | 1 (Option)          |
| RS232                 | 1 (Option)          |
| Digital IO            | 1 (Option)          |
| USB-GPIB              | 1 (Option)          |
| Rear output interface | Only DP811A has one |

| Environment         |   |
|---------------------|---|
| Working Temperature | DP831A/DP832A/DP832/DP811A:<br>Full rated value output: 0 $^{\circ}$ C $\sim$ 40 $^{\circ}$ C<br>Under relatively higher temperature: the linearity of the output current reduces to 50% at the highest temperature 55 $^{\circ}$ C<br><br>DP821A:<br>Full rated value output: 0 $^{\circ}$ C $\sim$ 40 $^{\circ}$ C<br>Under relatively higher temperature: the linearity of the output current reduces to 50% at the highest temperature 55 $^{\circ}$ C or the fuse is blown out |
| Storage Temperature | -40 $^{\circ}$ C $\sim$ 70 $^{\circ}$ C   |
| Humidity            | 5%~80%  |
| Altitude            | Operating: below 3 000 meters   |

|                |                                    |
|----------------|------------------------------------|
|                | Non-operating: below 15 000 meters |
| Cooling Method | Fan Cooling                        |

**Note**<sup>[1]</sup>: The accuracy parameters are acquired via calibration under 25°C after 1-hour warm-up.

**Note**<sup>[2]</sup>: When DP832 is installed with the accuracy option, its resolution is the same as that of DP832A.

**Note**<sup>[3]</sup>: The maximum time required for the output to change accordingly after receiving the [APPLY](#) and [SOURCE](#) commands.

**Note**<sup>[4]</sup>: The variation of the output within 8 hours after 30-minute warm-up when the load circuit and environment temperature are constant.